

MODEL 8849 4 BOTTLE NITROGEN CART

NITROGEN CART INCLUDES:

- 4 Bottle nitrogen storage rack with clamps for US DOT or European (large) bottles
- Conveniently located Control Manifold with bottle connect Tailpieces, Shutoff Valves, Bottle Charging Inlet Port, High Pressure Regulator for strut/accumulator charging, Low Pressure Regulator for tire servicing and Pressure Gages
- 4.00 x 8 (16 inch diameter) Poly Filled Tires eliminate flats due to punctures and provide a cushioned ride
- Heavy duty tubular steel construction
- Rugged large diameter tubular steel Tow Handle with integral adjustable Parking Brake and 3 inch lunette eye
- One 35' long High Pressure Service Hose with Strut Safety Chuck on Hose Rack
- One 35' long Low Pressure Service Hose with Tire Air Chuck on Hose Rack
- Protective Cover for Control Manifold

- All unpainted parts are plated to resist corrosion
- 1 Year Warranty
- Skydrol Resistant Paint (safety yellow)
- Pressure Gauges
- Shipping Skid

STANDARD OPTIONS:

- US DOT Standard 3600/4500 psig Nitrogen Bottles
- High and Low Pressure Retractable Hose Reels with 35' long Service Hoses and end connections
- Special Paint Color

Model 8849 is built to withstand harsh environmental conditions, rugged use and to provide many years of continuous service. Our customers are guaranteed a quality product with each purchase and are assured of our continued product support whenever and wherever the need arises.

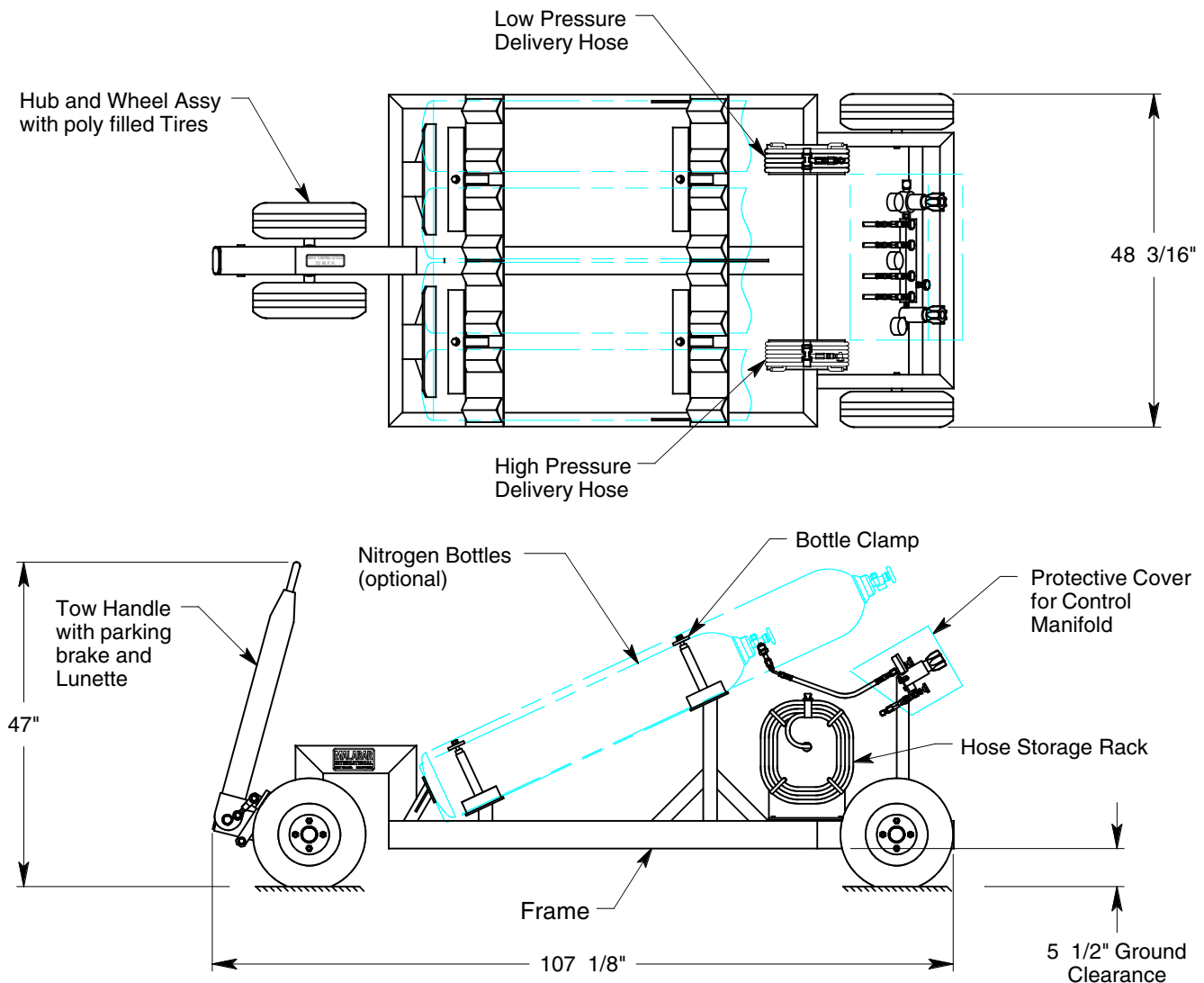

See Reverse Side for Specifications, Options & Shipping Data

MODEL 8849

4 BOTTLE NITROGEN CART

SPECIFICATIONS

Low Pressure Regulator: 0-300 psig (0-21 kg/sq cm)
 High Pressure Regulator: 0-4000 psig (0-281 kg/sq cm)
 Pressure Gauge: 0-300 psig (0-21 kg/sq cm)
 Pressure Gauge (2): 0-5000 psig (0-351 kg/sq cm)
 Nitrogen Shutoff Valves: 5000 psig (350 kg/sq cm)
 Nitrogen Charging Port: 1/4 37° Flare
 Maximum Towing Speed: 20 mph (32 km/h)
 Unit Weight (without nitrogen bottles): 580 lbs (263 kg)
 Unit Weight (with US DOT bottles): 1180 lbs (535 kg)

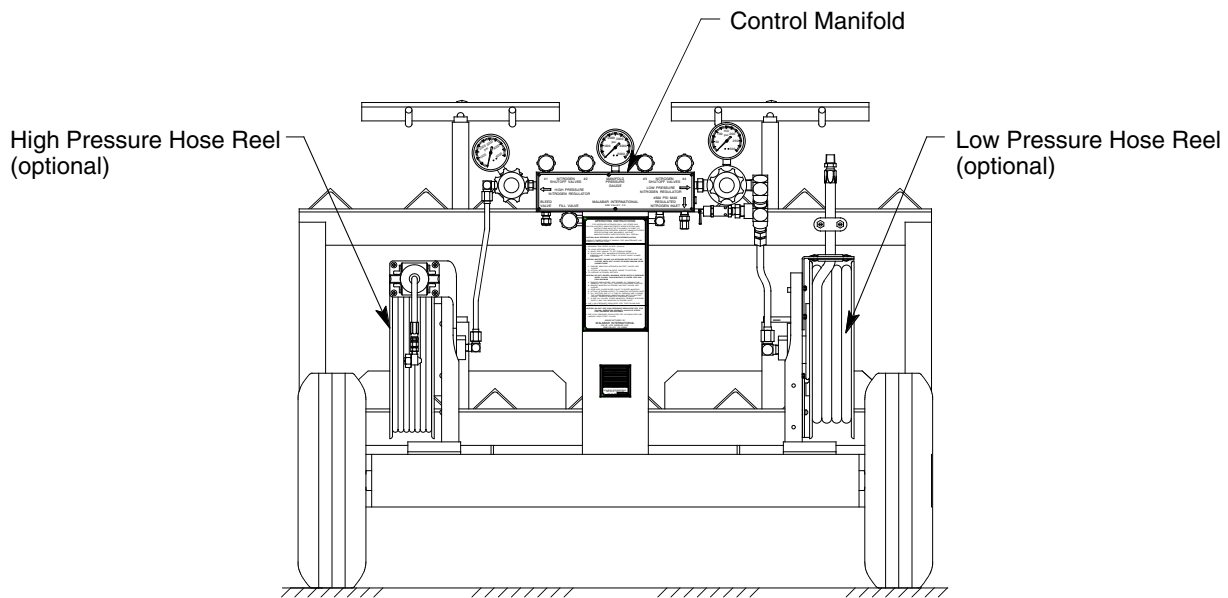

OPTIONAL EQUIPMENT CODES: (Specify at time of order)

HR: High and Low Pressure Hose Reels with 35 ft of Hose each
 NB: US DOT Standard 3600/4500 psig Nitrogen Bottles
 SPC: Special Paint Color (yellow is standard)

SHIPPING DATA

NOTE: Unless otherwise specified, Model 8849 is shipped on a wood skid and enclosed in a wood crate.

Length inch (mm)	Width inch (mm)	Height inch (mm)	Weight lbs (kg)
112 (2845)	55 (1397)	55 (1397)	900 (408)

MALABAR International

Issue: 2/10

PLANT: 220 WEST LOS ANGELES AVENUE, SIMI VALLEY, CALIFORNIA 93065 • (805) 581-0116 • FAX (805) 584-1624
 MAIL: P.O. BOX 367, SIMI VALLEY, CALIFORNIA 93062 • E-mail: sales@malabar.com • Web site: <http://www.malabar.com>