

MODEL 50P9AR 50 TON AUTO-RETRACT™ AXLE JACK

JACK INCLUDES:

- Double Acting Auto-Retract™ Cylinder Assembly incorporates a fluid bath for sealing surfaces to minimize corrosion and extend seal life. It also includes Skydrol resistant seals and bronze upper bearings for longer service life
- Auto-Retract™ Plungers remain fully retracted while jack is being towed or in storage to protect against corrosion, contaminants and accidental damage
- Single Valve Control for simple and easy aircraft raising, lowering and Auto-Retract™. Jack retracts to full retracted position automatically which provides for easy removal from under aircraft jack point after each operation
- Control Console with all controls conveniently mounted for ease of operation
- 8" diameter Heavy Duty Swivel Casters and Retractable Front Wheel with Skydrol resistant tread. The tow handle actuated Front Wheel provides improved ground clearance for towing
- Hydraulic Fuse at the cylinder assembly prevents lowering of load in the event of a fluid line failure

- Two Manual Hand Pumps (one high pressure, low volume and one low pressure, high volume)
- Oil Filter Cap with filtered air vent and dipstick
- Hard Chrome Plated Cylinder and Plunger Bores
- All unpainted parts are plated to resist corrosion
- Skydrol Resistant Paint (safety yellow)
- Factory Proof Load @ 150% of rated capacity
- 1 Year Warranty
- Fully Enclosed Shipping Container with Skid

STANDARD OPTIONS:

- Air Operated Hydraulic Pump
- Load Gauge for load indication (reads tons/psig)
- Air Line Lubricator (for air operated hydraulic pump)
- Rain Hat (covers cylinder assembly)

Model 50P9AR is built to withstand harsh environmental conditions, rugged use and to provide many years of continuous service. Our customers are guaranteed a quality product with each purchase and are assured of our continued product support whenever and wherever the need arises.

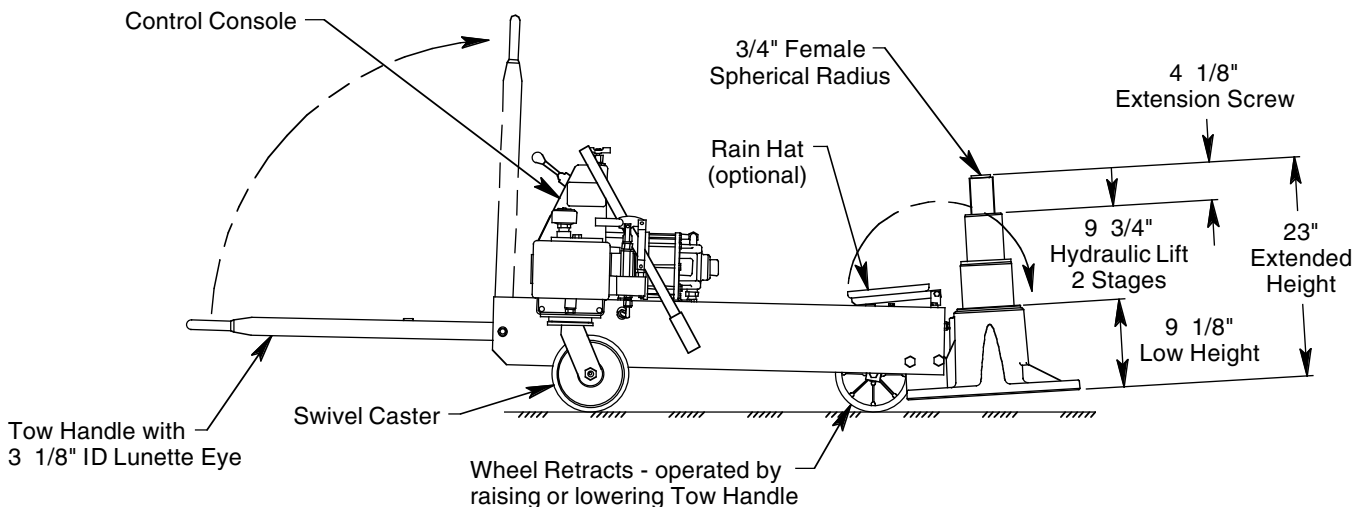
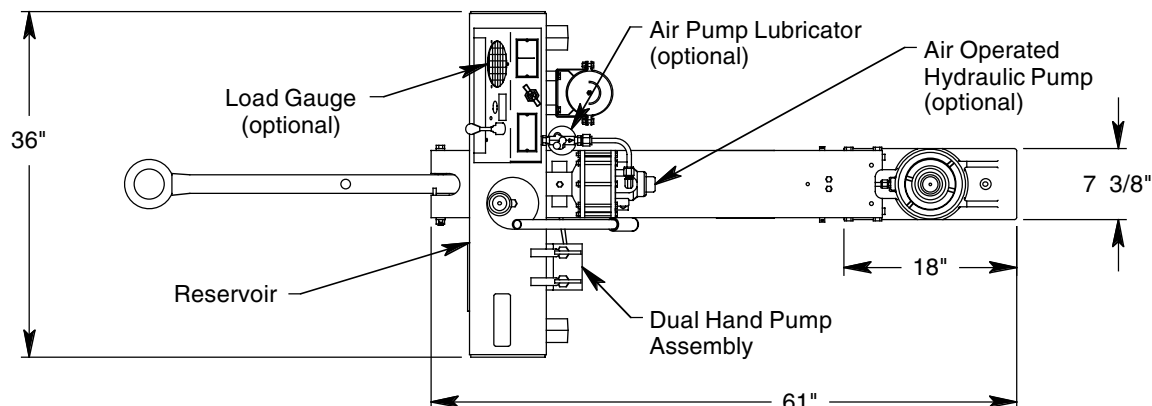

See Reverse Side for Specifications, Options, Aircraft Applications & Shipping Data

MODEL 50P9AR 50 TON AUTO-RETRACT™ AXLE JACK

SPECIFICATIONS

Rated Capacity: 50 tons (45.4 m. tons)
 Side Load: 15% of vertical load
 Low Height: 9.13 inches (232 mm)
 Hydraulic Lift: 9.75 inches (248 mm)
 Extension Screw: 4.13 inches (105 mm)
 Total Extended Height: 23 inches (584 mm)
 Base Width: 7.38 inches (187 mm)
 Cylinder Diameter: 7.38 inches (187 mm)
 Oil Pressure at Rated Capacity: 6660 psig (468 kg/sq cm)
 Safety Pop-off Valve set at: 53 tons (48.1 m. tons)
 Proof Load: 75 tons (68.0 m. tons)
 Floor Loading at Rated Capacity: 830 psi (58 kg/sq cm)
 Reservoir Capacity: 5.5 gallons (20.8 liters)
 Hydraulic Fluid: MIL-H-5606 or equivalent
 Maximum Towing Speed: 5 mph (8 km/h)
 Approximate Jack Net Weight: 450 lbs (204 kg)

MODEL 50P9AR TYPICAL AIRCRAFT APPLICATIONS

Main Landing Gear	Nose Landing Gear
A319, A320, A321, B717, B727, B737 B757, DC8, DC9, F100, MD80, MD90	A319, A320, A321, B757, B727

OPTIONAL EQUIPMENT CODES: (Specify at time of order)

AP: Air Operated Hydraulic Pump
 GA: Load Gauge
 LU: Lubricator (requires air operated hydraulic pump)
 RH: Rain Hat
 SPC: Special Paint Color (yellow is standard)

JACK ACCESSORIES: (Order separately)

50P9ARPK: Repair Kit
 871420: Tire Slave Kit (to operate air operated hydraulic pump from aircraft tire)
 880470: Lift Ring Kit (provides three lift points to lift jack assembly)
 881700: Model 8817 Universal Axle Jack Transporter (trailer for long distance, high speed towing)
 873828: Extender Kit (for B747-400ER NLG)

SHIPPING DATA

NOTE: Unless otherwise specified, Model 50P9AR jack is shipped on a wood skid with an enclosed cover. Refer to Malabar Axle Jack Shipping Supplement for additional packaging information.

Length inch (mm)	Width inch (mm)	Height inch (mm)	Weight lbs (kg)
70 (1778)	45 (1143)	39 (991)	510 (231)