

MODEL 832R 35 TON AXLE JACK

JACK INCLUDES:

- Cylinder Assembly includes Bronze lower Bearings for longer service life
- Single Valve Control for simple and easy aircraft raising and lowering
- 5" diameter Heavy Duty Swivel Casters and Retractable Front Wheel
- Retractable Spring Loaded Front Wheel provides improved ground clearance for towing
- Check Valve at the cylinder assembly prevents lowering of load in the event of a hose failure
- Two Manual Hand Pumps (one high pressure, low volume and one low pressure, high volume)
- Oil Filter Cap with filtered air vent and dipstick
- Hard Chrome Plated Cylinder and Plunger Bores
- All unpainted parts are plated to resist corrosion

- Skydrol Resistant Paint (safety yellow)
- Factory Proof Load @ 150% of rated capacity
- 1 Year Warranty
- Fully Enclosed Shipping Container with Skid

STANDARD OPTIONS:

- Air Operated Hydraulic Pump
- Air Retract (for fast plunger retraction)
- Load Gauge for load indication (reads tons/psig)
- Rain Hat (covers cylinder assembly)

Model 832R is built to withstand harsh environmental conditions, rugged use and to provide many years of continuous service. Our customers are guaranteed a quality product with each purchase and are assured of our continued product support whenever and wherever the need arises.

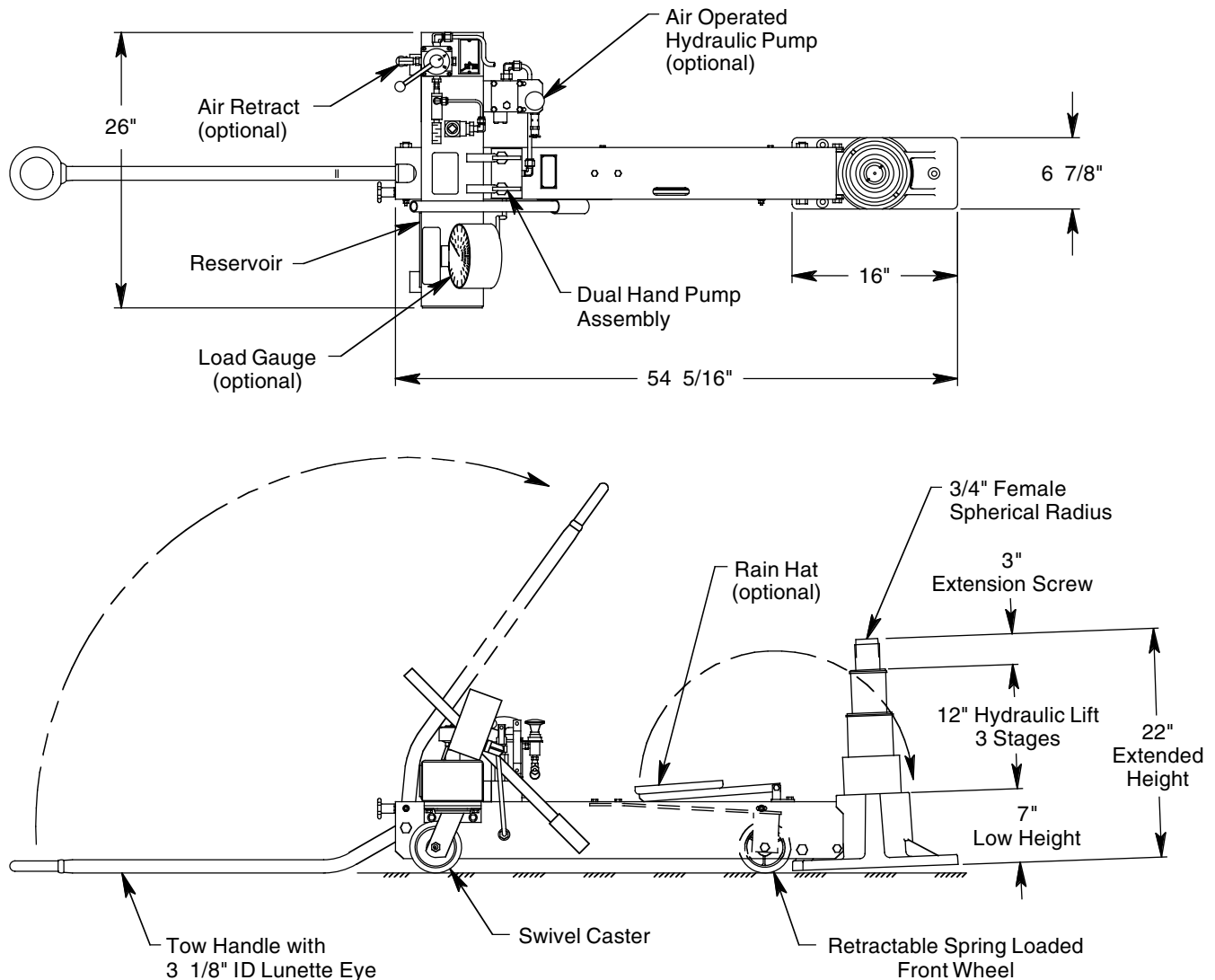

See Reverse Side for Specifications, Options, Aircraft Applications & Shipping Data

MODEL 832R 35 TON AXLE JACK

SPECIFICATIONS

Rated Capacity: 35 tons (31.8 m. tons)
 Low Height: 7 inches (178 mm)
 Hydraulic Lift: 12 inches (305 mm)
 Extension Screw: 3 inches (76 mm)
 Total Extended Height: 22 inches (559 mm)
 Base Width: 6.88 inches (175 mm)
 Cylinder Diameter: 6.88 inches (175 mm)
 Oil Pressure at Rated Capacity: 6770 psig (476 kg/sq cm)
 Safety Pop-off Valve set at: 38.5 tons (34.9 m. tons)
 Proof Load: 52.5 tons (47.6 m. tons)
 Floor Loading at Rated Capacity: 651 psi (46 kg/sq cm)
 Reservoir Capacity: 2 gallons (7.6 liters)
 Hydraulic Fluid: MIL-H-5606 or equivalent
 Maximum Towing Speed: 5 mph (8 km/h)
 Approximate Jack Net Weight: 360 lbs (163 kg)

MODEL 832R TYPICAL AIRCRAFT APPLICATIONS

Main Landing Gear	Nose Landing Gear
880, 890, A318, A319, B717, B737, B757, BAC 1-11, BAE146, C130, DC9 F28, F100, HS125, MD80, MD90	A318, A319, A320, A321, B737, B757, C130

OPTIONAL EQUIPMENT CODES: (Specify at time of order)

AP: Air Operated Hydraulic Pump
 GA: Load Gauge
 RH: Rain Hat
 AR: Air Retract (requires air operated hydraulic pump)
 SPC: Special Paint Color (yellow is standard)

JACK ACCESSORIES: (Order separately)

832RPK: Repair Kit
 871420: Tire Slave Kit (to operate air operated hydraulic pump from aircraft tire)

SHIPPING DATA

NOTE: Unless otherwise specified, Model 832R jack is shipped on a wood skid with an enclosed cover. Refer to Malabar Axle Jack Shipping Supplement for additional packaging information.

Length inch (mm)	Width inch (mm)	Height inch (mm)	Weight lbs (kg)
70 (1778)	45 (1143)	39 (991)	420 (191)