

MODEL 8782
35 TON "FLY-AWAY" AXLE JACK

JACK INCLUDES:

- Hard Chrome Plated Cylinder and Plunger Bores
- Extension Screw and Hand Pump parts are plated to resist corrosion
- Two Manual Hand Pumps (one high pressure, low volume and one low pressure, high volume)
- Air Operated Hydraulic Pump for power operation
- Skydrol Resistant Paint (safety yellow)
- Factory Proof Load @ 150% of rated capacity

- 1 Year Warranty
- Fully Enclosed Shipping Container

Model 8782 is built to withstand harsh environmental conditions, rugged use and to provide many years of continuous service. Our customers are guaranteed a quality product with each purchase and are assured of our continued product support whenever and wherever the need arises.

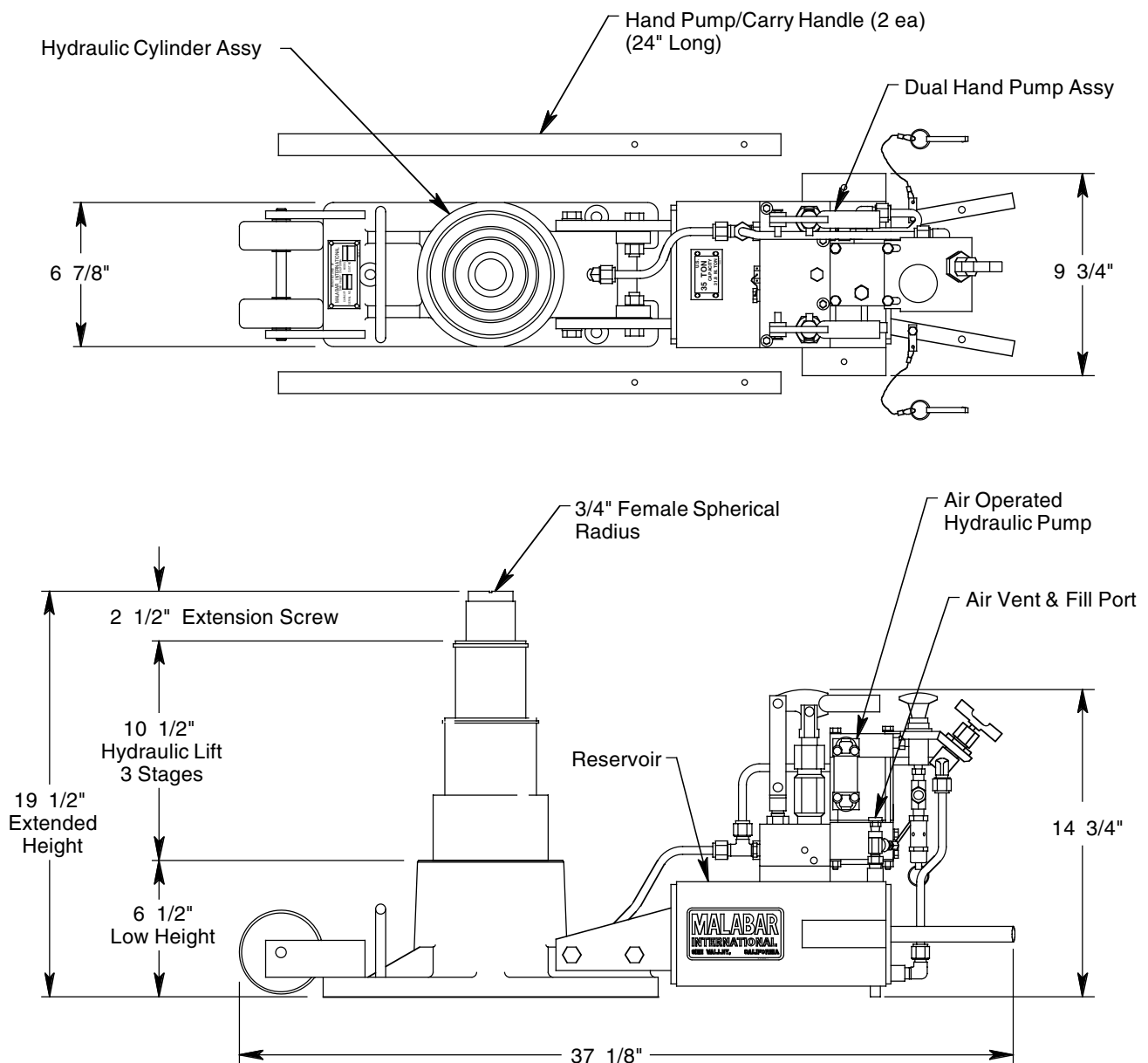

See Reverse Side for Specifications, Options, Aircraft Applications & Shipping Data

MODEL 8782

35 TON "FLY-AWAY" AXLE JACK

SPECIFICATIONS

Rated Capacity: 35 tons (31.8 m. tons)
 Side Load: 15% of vertical load
 Low Height: 6.5 inches (165 mm)
 Hydraulic Lift: 10.5 inches (267 mm)
 Extension Screw: 2.5 inches (64 mm)
 Total Extended Height: 19.5 inches (495 mm)
 Oil Pressure at Rated Capacity: 6760 psig (475 kg/sq cm)
 Safety Pop-off Valve set at: 38.5 tons (34.9 m. tons)
 Proof Load: 52.5 tons (47.6 m. tons)
 Reservoir Capacity: 1.1 gallons (4.2 liters)
 Hydraulic Fluid: MIL-H-5606 or equivalent
 Approximate Jack Net Weight: 155 lbs (70 kg)
 Total Handle Load (Wheeling): 40 lbs (18 kg)

MODEL 8782 TYPICAL AIRCRAFT APPLICATIONS

Main Landing Gear	Nose Landing Gear
880, 890, A318, A319, B717, B737 B757, BAC 1-11, BAE146, C130, DC9 F28, F100, HS125, MD80, MD90	A318, A319, A320, A321, B737, B757, C130

OPTIONAL EQUIPMENT CODES: (Specify at time of order)

SPC: Special Paint Color (yellow is standard)
 8782PK: Repair Kit

SHIPPING DATA

NOTE: Model 8782 jack is shipped in a fully enclosed shipping container.

Length inch (mm)	Width inch (mm)	Height inch (mm)	Weight lbs (kg)
42 (1067)	15 (381)	22 (559)	220 (100)