

MODEL 95P10AR 95 TON FLOATING AUTO-RETRACT™ AXLE JACK

JACK INCLUDES:

- Patented Floating™ Cylinder Assembly allows unit to track arc of landing gear jack point, eliminating excessive side loads on jack and landing gear thus providing safer operation and extending jack life
- Double Acting Auto-Retract™ Cylinder Assembly incorporates a fluid bath for sealing surfaces to minimize corrosion and extend seal life. It also includes Skydrol resistant seals for longer service life
- Auto-Retract™ Plungers remain fully retracted while jack is being towed or in storage to protect against corrosion, contaminants and accidental damage
- Single Valve Control for simple and easy aircraft raising, lowering and Auto-Retract™. Jack retracts to full retracted position automatically which provides for easy removal from under aircraft jack point after each operation
- Control Console with all controls conveniently mounted for ease of operation
- 8" diameter Heavy Duty Swivel Casters and Retractable Front Wheel with Skydrol resistant tread. The tow handle actuated Front Wheel provides improved ground clearance for towing

- Hydraulic Fuse at the cylinder assembly prevents lowering of load in the event of a hose failure
- Two Manual Hand Pumps (one high pressure, low volume and one low pressure, high volume)
- Oil Filter Cap with filtered air vent and dipstick
- Hard Chrome Plated Cylinder and Plunger Bores
- All unpainted parts are plated to resist corrosion
- Skydrol Resistant Paint (safety yellow)
- Factory Proof Load @ 125% of rated capacity
- 1 Year Warranty
- Fully Enclosed Shipping Container with Skid

STANDARD OPTIONS:

- Standard Air Operated Hydraulic Pump
- High Speed Air Operated Hydraulic Pump
- Load Gauge for load indication (reads tons/psig)
- Air Line Lubricator (for air operated hydraulic pump)
- Rain Hat (covers cylinder assembly)

Model 95P10AR is built to withstand harsh environmental conditions, rugged use and to provide many years of continuous service. Our customers are guaranteed a quality product with each purchase and are assured of our continued product support whenever and wherever the need arises.

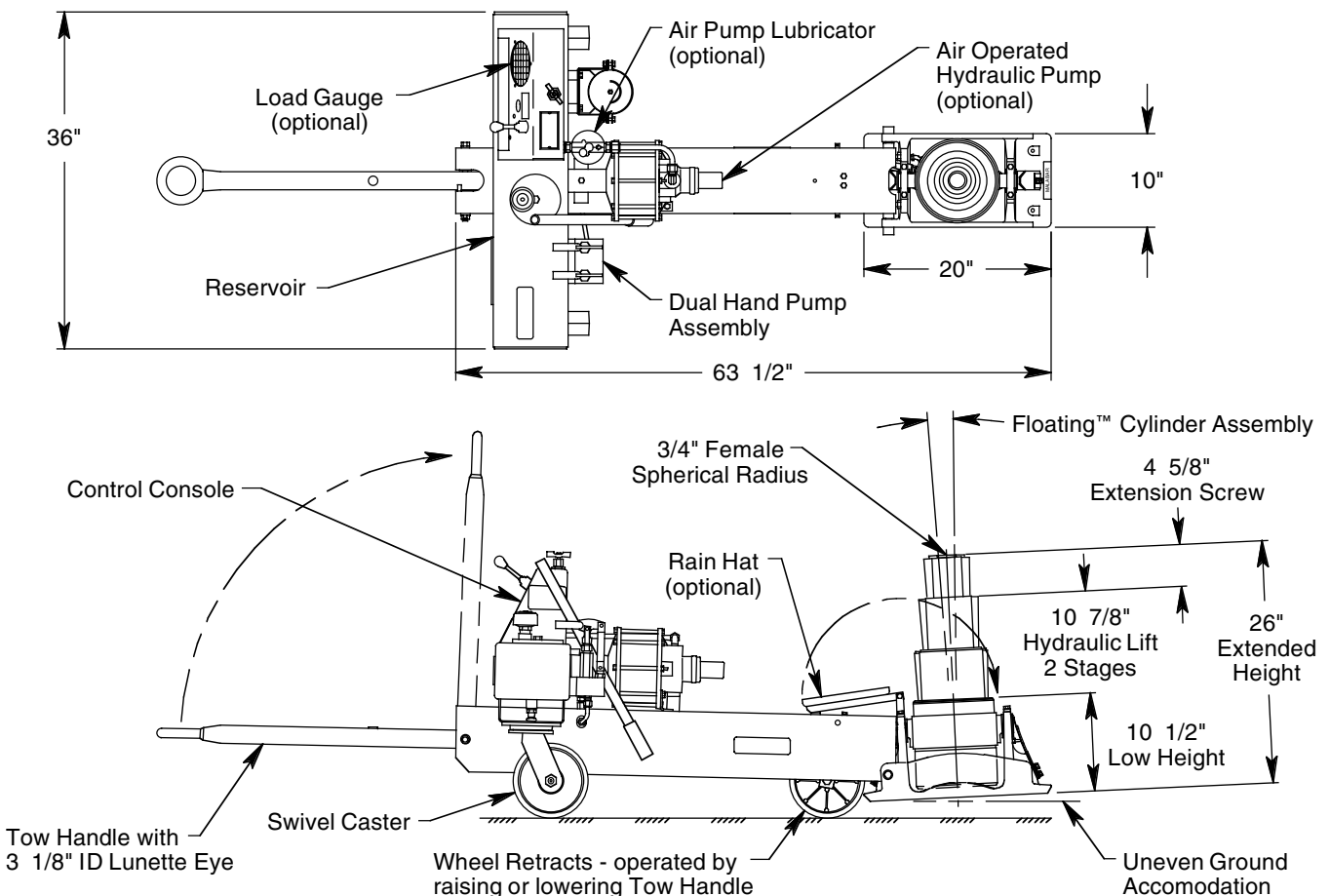

See Reverse Side for Specifications, Options, Aircraft Applications & Shipping Data

MODEL 95P10AR

95 TON FLOATING AUTO-RETRACT™ AXLE JACK

SPECIFICATIONS	
Rated Capacity:	95 tons (86 m. tons)
Low Height:	10.5 inches (267 mm)
Hydraulic Lift:	10.88 inches (276 mm)
Extension Screw:	4.62 inches (117 mm)
Total Extended Height:	26 inches (660 mm)
Total Extended Height w/ Extender Kit:	28 inches (711 mm)
Base Width:	10 inches (254 mm)
Cylinder Diameter:	9 inches (229 mm)
Oil Pressure at Rated Capacity:	8000 psig (562 kg/sq cm)
Safety Pop-off Valve set at:	101 tons (92 m. tons)
Proof Load:	118 tons (107.0 m. tons)
Floor Loading at Rated Capacity:	1000 psi (70 kg/sq cm)
Reservoir Capacity:	5.5 gallons (20.8 liters)
Hydraulic Fluid:	MIL-H-5606 or equivalent
Maximum Towing Speed:	5 mph (8 km/h)
Approximate Jack Net Weight:	580 lbs (263 kg)

MODEL 95P10AR TYPICAL AIRCRAFT APPLICATIONS	
Main Landing Gear	Nose Landing Gear
A300, A310, A319, A320, A321, A330 A340, B727, B737, B747, B747-8, B767 B777*, DC8, DC10, L1011, MD11	A300, A310, A330, A340, B727, B747 B747-8, B767, B777, L1011
*Two 95P10AR jacks are required for this application	

OPTIONAL EQUIPMENT CODES: (Specify at time of order)

- LP: Standard Air Operated Hydraulic Pump
- HP: High Speed Air Operated Hydraulic Pump
- GA: Load Gauge
- LU: Lubricator (requires air operated hydraulic pump)
- RH: Rain Hat
- SPC: Special Paint Color (yellow is standard)

JACK ACCESSORIES: (Order separately)

- 95P10ARPK: Repair Kit
- 871420: Tire Slave Kit (to operate air operated hydraulic pump from aircraft tire)
- 880470: Lift Ring Kit (provides three lift points to lift jack assembly)
- 881700: Model 8817 Universal Axle Jack Transporter (trailer for long distance, high speed towing)
- 880428: 2" Extender Kit (for B747-400ER NLG)

SHIPPING DATA			
NOTE: Unless otherwise specified, Model 95P10AR jack is shipped on a wood skid with an enclosed cover. Refer to Malabar Axle Jack Shipping Supplement for additional packaging information.			
Length inch (mm)	Width inch (mm)	Height inch (mm)	Weight lbs (kg)
70 (1778)	45 (1143)	39 (991)	640 (290)