

## MODEL 250 2 GALLON TURBINE OIL DISPENSER

### DISPENSER INCLUDES:

- Durable, Lightweight and Portable 2 gallon capacity Reservoir with integral Carrying Handle made from specially formulated "HS" Crosslinked Polyethylene material that is impervious to petroleum based fluids, hydraulic fluids, UV, solvents and cleaning solutions. "HS" units maintain a very high impact strength even at sub-zero temperatures and are available in several colorfast colors for easy identification of proper fluid type
- Manual Hand Pump and Inline Filter to dispense clean filtered aircraft fluids into aircraft systems
- Large Fillport
- 1 Year Warranty
- Fully Enclosed shipping container

### STANDARD OPTIONS:

- "HS" Polyethylene colorfast colors or polished stainless steel fluid tanks
- 3 micron absolute Filter or 1 micron Waterstop Filter
- Mechanical Fluid Totalizing Meters
- Discharge Pressure Gauges
- Lockable Fillport / Inlet Air Dryer
- Various Turbine Oil Fluid Placards are available to ensure compliance with customer and aircraft manufacturer's line maintenance requirements
- Standard and special Hose End Fittings and Couplings
- Delivery Hose compatible with dispensed fluid
- Accessories and Repair Kits

Model 250 is built to withstand harsh environmental conditions, rugged use and to provide many years of continuous service. Our customers are guaranteed a quality product with each purchase and are assured of our continued product support whenever and wherever the need arises.

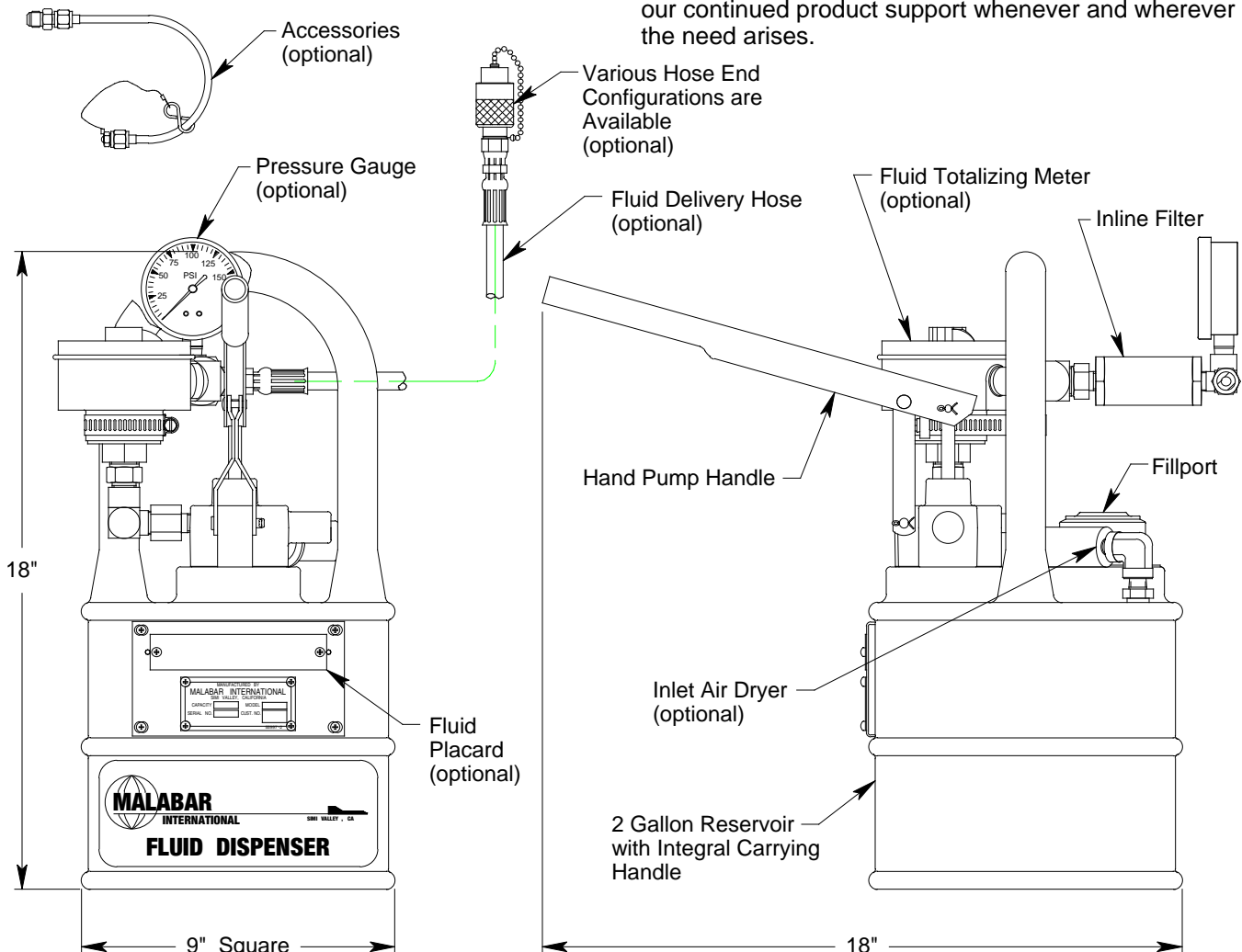

# MODEL 250 2 GALLON TURBINE OIL DISPENSER

## SPECIFICATIONS

Fluid Type: Turbine Oil  
 Fluid Capacity: 2 Gallon (7.6 liters)  
 Unit Displacement per Stroke: 2.5 cu. in. (41 cc)  
 Maximum Pump Outlet Pressure: 100 psig (7 kg/sq cm)  
 Standard Hose Length: 84 inches (2134 mm)  
 Standard Filter Rating: 2-3 micron nominal  
 Net Weight "HS" Tank: 12 lbs (5.4 kg)  
 Net Weight Stainless Steel Tank: 18 lbs (8.2 kg)

## MODEL 250 AIRCRAFT APPLICATIONS

Turbine Oil for Aircraft Engines, APU's, CSD's, and IDG's

### ORDERING CODE: 250G - 01 - 1 - 0 - 1 - 01 - 0 - 0 - AB

#### FLUID TANK CONFIGURATION:

**250G:** Polyethylene, Green  
**250Y:** Polyethylene, Yellow  
**250B:** Polyethylene, Blue  
**250S:** Stainless Steel, Polished

#### FLUID DESIGNATION & PLACARD:

**00:** No Fluid Placard  
**01:** Turbo Oil 2380  
**02:** Engine / CSD Oil  
**03:** Turbine Oil  
**04:** Not for Main Engine Use, APU Type 1  
     Oil ETO 2389 (use yellow tank)  
**05:** Mobil Jet II  
**06:** Esso 2380  
**07:** Exxon 2380  
**08:** MIL-L-7808  
**09:** Exxon 2380 Engine & Acc'y Oil  
**10:** Esso-TJ15 Turbo Compressor Oil  
**11:** Turbo Oil 2197 (use blue tank)  
**12:** Coolanol  
**XX:** Other (contact Malabar Sales)

#### FILTER TYPE:

**1:** Standard Filter  
**2:** 3 Micron Absolute Filter  
**3:** 1 Micron Nominal Waterstop Filter

#### FLUID TOTALIZING METER:

**0:** No Fluid Meter  
**1:** Mechanical Meter, quarts & pints  
**2:** Mechanical Meter, liters  
**3:** Discontinued

#### DELIVERY HOSE:

**0:** No Delivery Hose  
**1:** Standard Hose, 84" (7 ft) long  
**2:** Special Hose, 120" (10 ft) long  
**3:** Special Hose, 240" (20 ft) long  
**4:** Special Hose, 288" (24 ft) long  
**5:** Special Hose, 48" (4 ft) long  
**X:** Other (contact Malabar Sales)

#### \*ACCESSORIES:

**A:** Overflow Hose & Coupling for IDG/CSD Service (PF55951)  
**B:** Wetspline Adapter, CSD Only (PF53175)  
**C:** Overflow Hose & 90° elbow with 3/4-16 UNF 37° Female Swivel (PF56084)  
**D:** Repair Kit  
**XX:** Other (contact Malabar Sales)  
 \*Accessories are supplied as separate line items

#### FILLPORT / INLET AIR DRYER:

**0:** No Locking Port & No Air Dryer  
**1:** Locking Fillport Only  
**2:** Inlet Air Dryer & Non-vented Fillport

#### PRESSURE GAUGE:

**0:** No Pressure Gauge  
**1:** Standard Pressure Gauge  
**2:** Digital Pressure Gauge

#### HOSE END CONFIGURATION:

**01:** 9/16-18 UNF 37° Female Swivel  
**02:** 3/16 Tube with 90° Bend & 37° Flared 'B' Nut & Dust Plug (PF53339)  
**03:** 2506 Coupling (736-013) & Dust Plug  
**04:** 2506 Coupling (736-013), Dust Plug & Gravity Fill Adapter (PF55759)  
**05:** 2506 Coupling (736-013) with 45° Elbow (PF55817) & Dust Plug  
**06:** 7/16-20 UNF 37° Male with O-ring Seal (721-042)  
**07:** 1/4 Straight Tube & 37° Flared 'B' Nut & Dust Plug (PF55805)  
**08:** 2505 Coupling (736-015) & Dust Plug  
**09:** VEAC4-4F (716-023) with Swage Sleeves & Dust Plug  
**10:** 1/4 'U' Tube with 37° Flared 'B' Nut (PF53681), Dust Plug & Shutoff Valve  
**11:** VEAC4-4F (716-023) & Dust Plug with Adapter (PFCG10045-4)  
**XX:** Other (contact Malabar Sales)

## SHIPPING DATA

Length inch (mm)	Width inch (mm)	Height inch (mm)	Weight lbs (kg)
12 (305)	12 (305)	25 (635)	29 (13)

**MALABAR International**

Issue: 8/04

PLANT: 220 WEST LOS ANGELES AVENUE, SIMI VALLEY, CALIFORNIA 93065 • (805) 581-0116 • FAX (805) 584-1624  
 MAIL: P.O. BOX 367, SIMI VALLEY, CALIFORNIA 93062 • E-mail: sales@malabar.com • Web site: http://www.malabar.com