

MODEL 380
5 GALLON TURBINE OIL DISPENSER

DISPENSER INCLUDES:

- Durable, Lightweight and Portable 5 gallon capacity Stainless Steel Reservoir with Fluid Level Indicator and integral stainless steel Handle / Axle assembly with wheels
- Dual Manual Hand Pumps (low pressure high flow, high pressure low flow) and Inline Filter to dispense clean filtered aircraft fluids into aircraft systems
- Discharge Pressure Gauge
- Large Fillport
- 1 Year Warranty
- Fully Enclosed shipping container

STANDARD OPTIONS:

- 3 micron absolute Filter or 1 micron Waterstop Filter
- Mechanical Fluid Totalizing Meters
- Digital Discharge Pressure Gauge
- Lockable Fillport / Storage Tray
- Various Turbine Oil Fluid Placards are available to ensure compliance with customer and aircraft manufacturer's line maintenance requirements
- Standard and special Hose End Fittings and Couplings
- Polyurethane Wheels
- Delivery Hose compatible with dispensed fluid
- Accessories and Repair Kits

Model 380 is built to withstand harsh environmental conditions, rugged use and to provide many years of continuous service. Our customers are guaranteed a quality product with each purchase and are assured of our continued product support whenever and wherever the need arises.

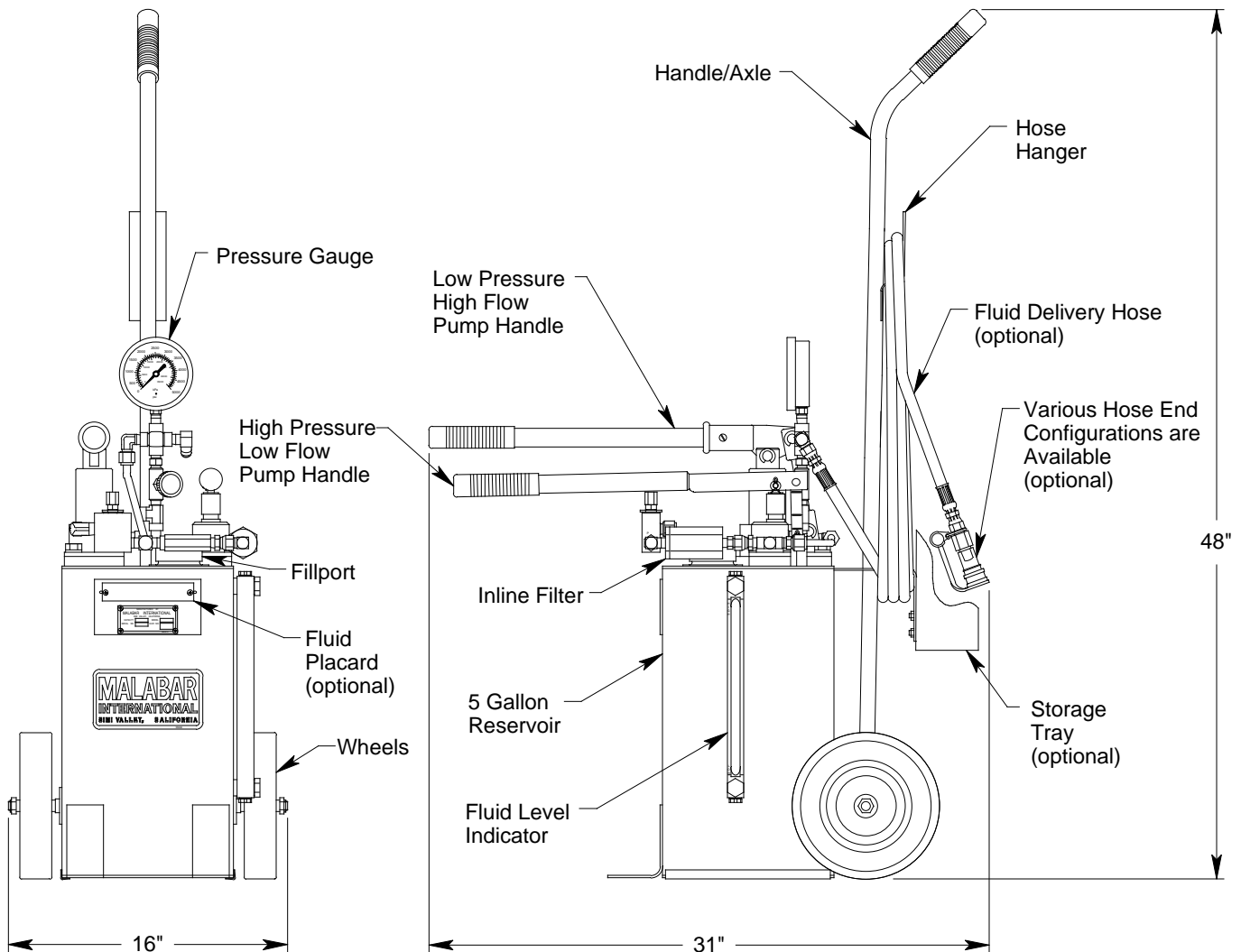

See Reverse Side for Specifications, Options & Shipping Data

MODEL 380

5 GALLON TURBINE OIL DISPENSER

SPECIFICATIONS

Fluid Type: Turbine Oil
 Fluid Capacity: 5 Gallon (18.9 liters)
 Pump Displacement
 High Pressure per Stroke: .14 cu in (2.3 cc)
 Low Pressure per Stroke: 1.8 cu in (30 cc)
 Maximum Pump Outlet Pressure
 High Pressure: 5000 psig (352 kg/sq cm)
 Low Pressure: 500 psig (35 kg/sq cm)
 Standard Hose Length: 240 inches (6096 mm)
 Standard Filter Rating: 2-3 micron nominal
 Net Weight : 55 lbs (25 kg)

MODEL 380 AIRCRAFT APPLICATIONS

Engine Duct Reverser Actuator Service Unit

ORDERING CODE: **380S -01 -1 -1 -01 -1 -0 -1 -A**

FLUID TANK CONFIGURATION:

380S: Stainless Steel, Polished

FLUID DESIGNATION & PLACARD:

00: No Fluid Placard

01: Reverser Duct Actuator Mobil Jet II

02: Reverser Duct Actuator MIL-L-7808
Engine Oil

03: Reverser Duct Actuator Esso 2380
Engine Oil

XX: Other (contact Malabar Sales)

FILTER TYPE:

1: Standard Filter

DELIVERY HOSE:

0: No Delivery Hose

1: Standard Hose, 240" (20 ft) long

X: Other (contact Malabar Sales)

***ACCESSORIES:**

A: Repair Kit

XX: Other (contact Malabar Sales)

*Accessories are supplied as separate line items

WHEELS:

1: Standard Rubber Wheels

2: Polyurethane Wheels

FILLPORT / STORAGE TRAY:

0: No Locking Fillport & No Storage Tray

1: Locking Fillport Only

2: Storage Tray Only

3: Storage Tray & Locking Fillport

PRESSURE GAUGE:

1: Standard Pressure Gauge

2: Digital Pressure Gauge

HOSE END CONFIGURATION:

01: 9/16-18 UNF 37° Female Swivel

02: #LL-2-H-8M Coupling (736-020) & Dust Plug

XX: Other (contact Malabar Sales)

SHIPPING DATA

Length inch (mm)	Width inch (mm)	Height inch (mm)	Weight lbs (kg)
22 (559)	17 (432)	49 (1244)	62 (28)