

MODEL 475 15 GALLON HYDRAULIC (MIL-H-5606) DISPENSER

DISPENSER INCLUDES:

- Durable, Lightweight and Portable 15 gallon capacity Stainless Steel Reservoir with integral Handles and Axle with polyurethane Wheels
- Air Operated Hydraulic Pump, Manual Hand Pump and Inline Filter to dispense clean filtered aircraft fluids into aircraft systems
- Fluid Level Gauge
- Large Fillport
- 1 Year Warranty
- Fully Enclosed shipping container

STANDARD OPTIONS:

- 3 micron absolute Filter
- Discharge Pressure Gauge
- Lockable Fillport
- Mechanical Fluid Totalizing Meters
- Standard and special Hose End Fittings and Couplings
- Delivery Hose compatible with dispensed fluid
- Accessories and Repair Kits

Model 475 is built to withstand harsh environmental conditions, rugged use and to provide many years of continuous service. Our customers are guaranteed a quality product with each purchase and are assured of our continued product support whenever and wherever the need arises.

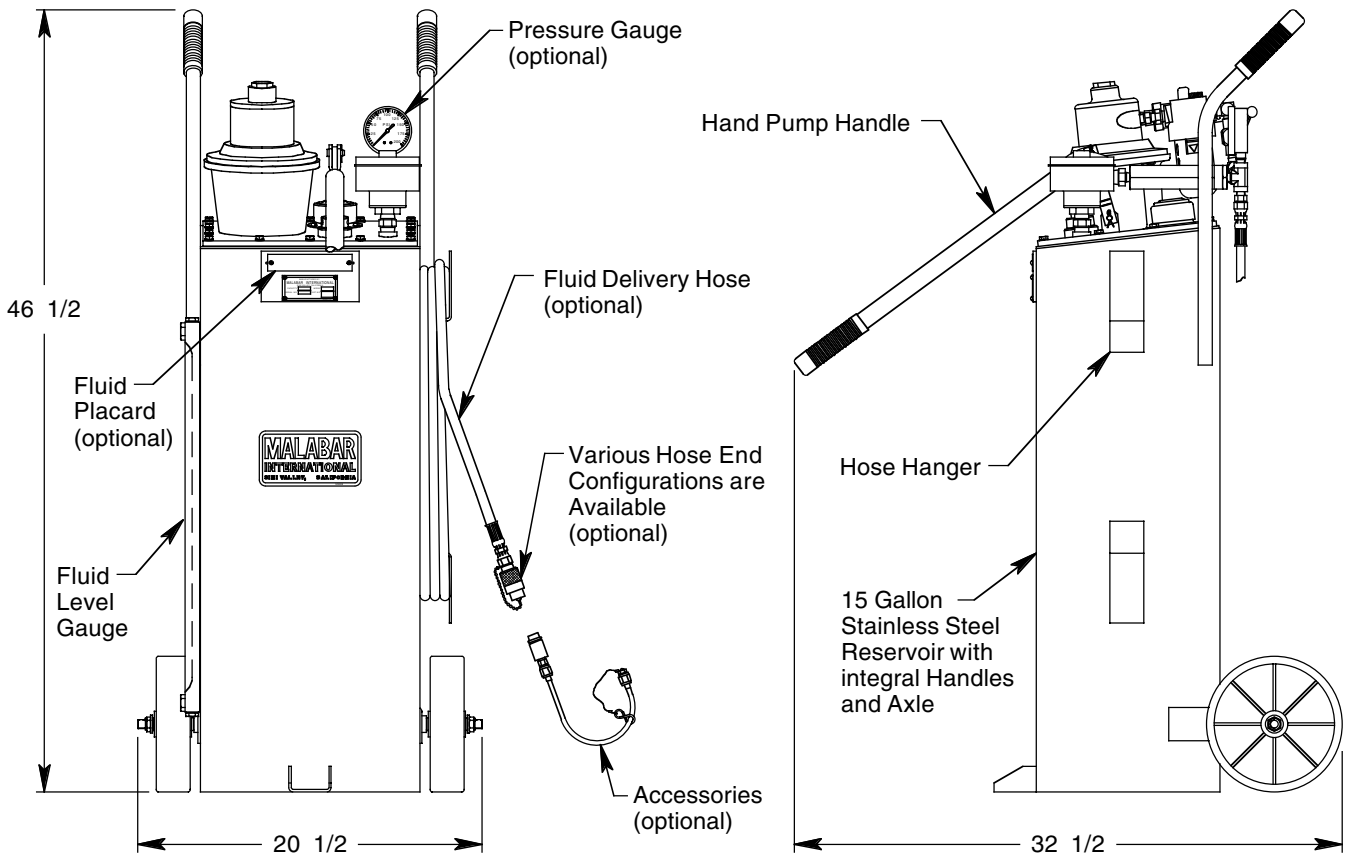
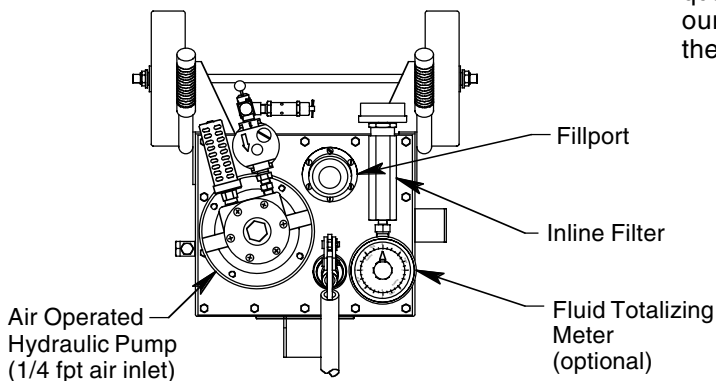

See Reverse Side for Specifications, Options & Shipping Data

MODEL 475

15 GALLON HYDRAULIC (MIL-H-5606) DISPENSER

SPECIFICATIONS

Fluid Type: MIL-H-5606 or Equal
 Fluid Capacity: 15 Gallon (56.8 liters)
 Hand Pump Displacement per Stroke: 4.0 cu. in. (66 cc)
 Maximum Air Operated Pump Flow: 4.5 gpm (17.0 liters)
 Maximum Pump Outlet Pressure: 100 psig (7 kg/sq cm)
 Standard Hose Length: 120 inches (3048 mm)
 Standard Filter Rating: 2-3 micron nominal
 Net Weight: 105 lbs (47.6 kg)

MODEL 475 AIRCRAFT APPLICATIONS

MIL-H-5606 or Equal Fluids for Aircraft Struts & Hydraulic Systems

ORDERING CODE: 475S - 01 - 1 - 0 - 1 - 01 - 0 - 0 - A

FLUID TANK CONFIGURATION: _____

475S: Stainless Steel, Polished

FLUID DESIGNATION & PLACARD: _____

- 00:** No Fluid Placard
- 01:** MIL-H-5606
- 02:** Royco SSF-BMS 3-32 Type 1
- 03:** Royco SSF
- 04:** Royco LGF
- XX:** Other (contact Malabar Sales)

FILTER TYPE: _____

- 1:** Standard Filter
- 2:** 3 Micron Absolute Filter

FLUID TOTALIZING METER: _____

- 0:** No Fluid Meter
- 1:** Mechanical Meter, quarts & pints
- 2:** Mechanical Meter, liters

DELIVERY HOSE: _____

- 0:** No Delivery Hose
- 1:** Standard Hose, 120" (10 ft) long
- 2:** Special Hose, 240" (20 ft) long
- X:** Other (contact Malabar Sales)

***ACCESSORIES:**

- A:** Repair Kit
- XX:** Other (contact Malabar Sales)

*Accessories are supplied as separate line items

FILLPORT:

- 0:** No Locking Fillport
- 1:** Locking Fillport

PRESSURE GAUGE:

- 0:** No Pressure Gauge
- 1:** Standard Pressure Gauge

HOSE END CONFIGURATION:

- 01:** 9/16-18 UNF 37° Female Swivel
- 02:** 100 Coupling (736-010) & Dust Plug
- 03:** 6116 Coupling (719-045)
- 04:** 7/16-20 UNF 37° Female Swivel with 45° Elbow (PF55877)
- 05:** 9/16-18 UNF 37° Female Swivel & Dust Plug
- XX:** Other (contact Malabar Sales)

SHIPPING DATA

Length inch (mm)	Width inch (mm)	Height inch (mm)	Weight lbs (kg)
50 (1270)	28 (711)	29 (737)	260 (118)