

MODEL 65L4.5 65 TON FLOATING BEAM ASSEMBLY

BEAM INCLUDES:

- Patented Floating™ Beam Assembly allows emergency dual flat or on rims jacking in conjunction with a Malabar 65P10 or 65P10AR Floating "Auto Retract" Axle Jack
- 12" diameter Heavy Duty Wheels with Skydrol resistant tread
- Tow Handle with 3" Lunette Eye for towing
- All unpainted parts are plated to resist corrosion
- Skydrol Resistant Paint (safety yellow)
- Factory Proof Load @ 150% of rated capacity
- 1 Year Warranty
- Shipping Skid

Model 65L4.5 is built to withstand harsh environmental conditions, rugged use and to provide many years of continuous service. Our customers are guaranteed a quality product with each purchase and are assured of our continued product support whenever and wherever the need arises.

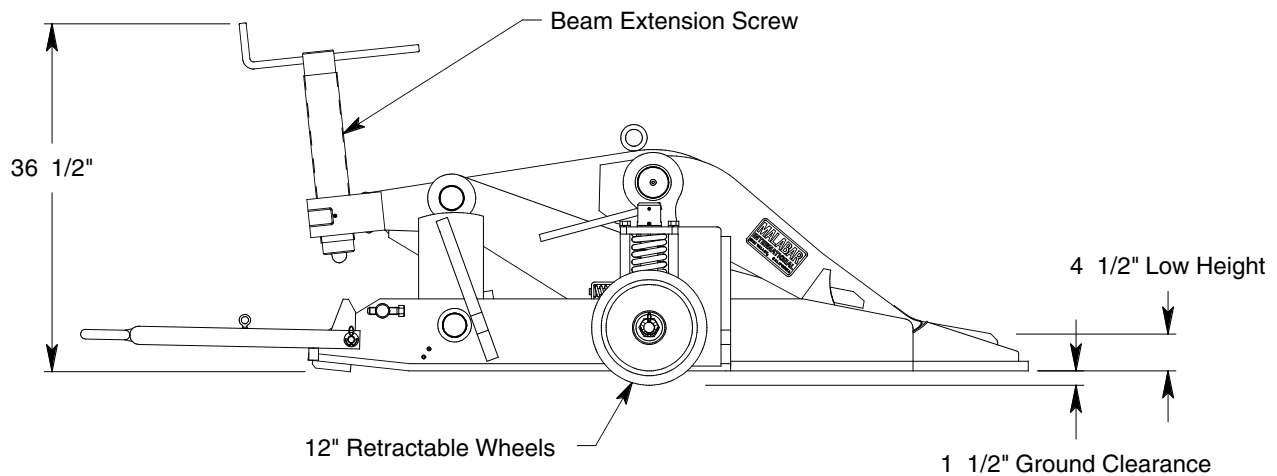
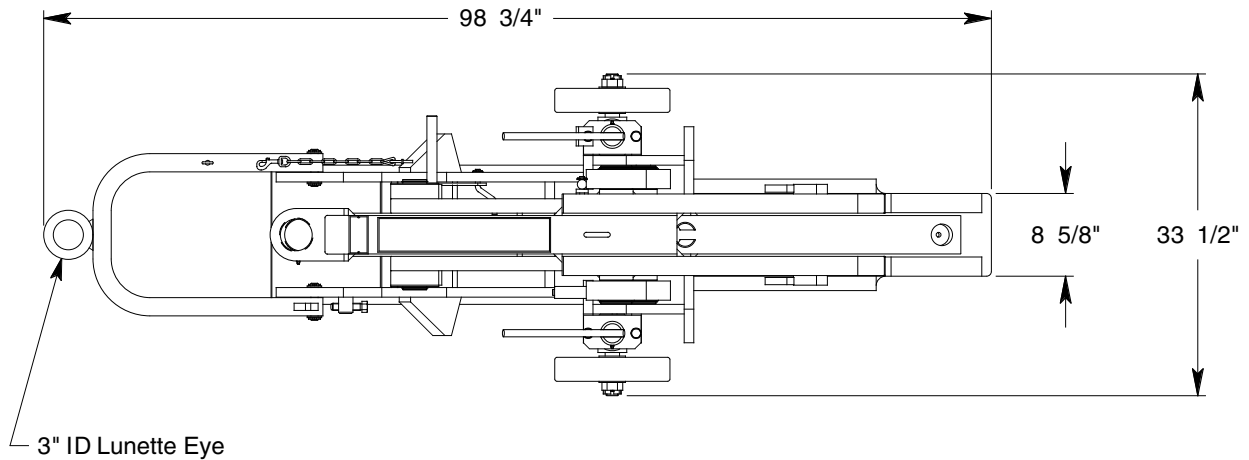

MODEL 65L4.5 65 TON FLOATING BEAM ASSEMBLY

SPECIFICATIONS

Rated Capacity:	65 tons (59.0 m. tons)
Low Height with standard adapter:	4.5 inches (114 mm)
Low Height with 747 NLG adapter:	8.5 inches (216 mm)
Lift (provided by Malabar jack/beam extension screw):	17.5 inches (445 mm)
Total Extended Height with standard adapter:	22 inches (559 mm)
Total Extended Height with 747 NLG adapter:	26 inches (660 mm)
Base Width (under jack point):	8.6 inches (220 mm)
Beam Width (under jack point):	4 inches (102 mm)
Proof Load:	97.5 tons (88.5 m. tons)
Maximum Towing Speed	5 mph (8 km/h)
Approximate Beam Net Weight:	2400 lbs (1089 kg)

MODEL 65L4.5 TYPICAL AIRCRAFT APPLICATIONS

Main Landing Gear	Nose Landing Gear
A300, A310, A319, A320, A321, A330, B707, B720, B727, B737, B747, B747-8, B757, B767, B787, DC10, MD11	A300, A310, A330, B747, B747-8, B767, B787

OPTIONAL EQUIPMENT CODE: (Specify at time of order)
 SPC: Special Paint Color (yellow is standard)

BEAM ACCESSORIES: (Order separately)
 65P10AR: 65 Ton Axle Jack (provides lift for beam)

PACKAGING CODES & OPTIONS: (Specify at time of order)
 — : Domestic Skid
 EC: Export Crate (Additional Cost)

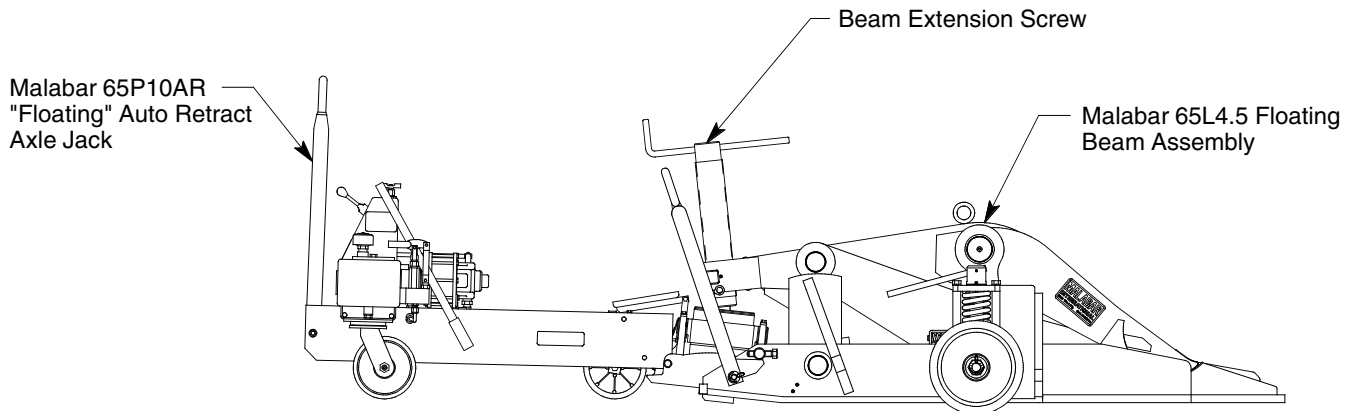

SHIPPING DATA

NOTE: Unless otherwise specified, Model 65L4.5 beam is shipped on a wood skid.

Packaging Code	Length inch (mm)	Width inch (mm)	Height inch (mm)	Weight lbs (kg)
—	82 (2083)	40 (1016)	40 (1016)	2500 (1134)
EC	84 (2134)	45 (1143)	43 (1092)	2800 (1270)