

MODEL 8616B 15 TON BEAM KIT WITH (2) TWO STAGE HYDRAULIC AVIATION AXLE JACKS

AXLE JACK INCLUDES:

- Hard Chrome Plated Cylinder and Plunger Bores
- Extension screw and hand pump parts are plated to resist corrosion
- Manual Hand Pump
- Skydrol Resistant Paint (safety yellow)
- Factory Proof Load @ 150% of rated capacity
- 1 Year Warranty
- Fully Enclosed Shipping Container

Model 8616B is built to withstand harsh environmental conditions, rugged use and to provide many years of continuous service. Our customers are guaranteed a quality product with each purchase and are assured of our continued product support whenever and wherever the need arises.

BEAM:

- 15 Ton capacity designed primarily for use in jacking the main and/or nose landing gear of various aircraft (with dual flats or on-rim conditions) when used in conjunction with two 8693A axle jacks.

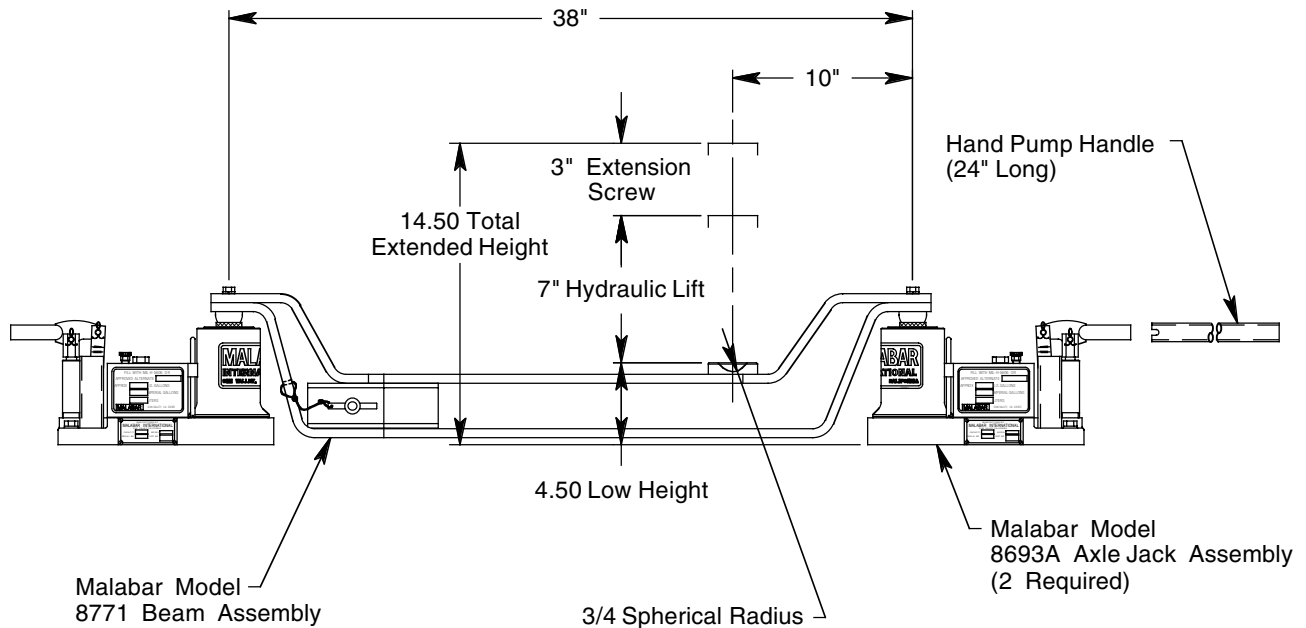

MODEL 8616B

15 TON BEAM KIT WITH (2) TWO STAGE HYDRAULIC AVIATION AXLE JACKS

MODEL 8693A AXLE JACK SPECIFICATIONS

Rated Capacity: 12 tons (10.9 m. tons)
 Side Load: 15% of vertical load
 Low Height: 6.75 inches (171 mm)
 Hydraulic Lift: 7 inches (178 mm)
 Extension Screw: 3 inches (76 mm)
 Total Extended Height: 16.75 inches (425 mm)
 Oil Pressure at Rated Capacity: 6170 psig (434 kg/sq cm)
 Safety Pop-off Valve set at: 13.2 tons (12.0 m. tons)
 Proof Load: 18 tons (16.3 m. tons)
 Reservoir Capacity: 0.2 gallons (0.8 liters)
 Hydraulic Fluid: MIL-H-5606 or equivalent
 Approximate Jack Net Weight: 36 lbs (16 kg)

MODEL 8771 BEAM SPECIFICATIONS

Rated Capacity: 15 tons (13.6 m. tons)
 Low Height: 4.50 inches (114 mm)
 Extension Screw from Axle Jack: 3 inches (76 mm)
 Hydraulic Lift from Axle Jack: 7 inches (178 mm)
 Total Extended Height: 14.50 inches (386 mm)
 Beam Weight: 75 lbs (16 kg)
 Test Load: 22.5 tons (20.4 m. tons)

MODEL 8616B TYPICAL AIRCRAFT APPLICATIONS

Nose Landing Gear	Main Landing Gear
601, 602, B737, DC9, MD80, MD90	601, 602

OPTIONAL EQUIPMENT CODES: (Specify at time of order)
 SPC: Special Paint Color (yellow is standard)
 8693APK: Repair Kit

SHIPPING DATA

NOTE: Model 8616B beam assy is shipped in a fully enclosed shipping container.

Length inch (mm)	Width inch (mm)	Height inch (mm)	Weight lbs (kg)
44 (1118)	12 (305)	18 (457)	180 (82)