

MODEL 95L5.0 95 TON FLOATING BEAM ASSEMBLY

BEAM INCLUDES:

- Patented Floating™ Beam Assembly allows emergency dual flat or on rims jacking in conjunction with a Malabar 95P10AR Floating "Auto Retract" Axle Jack
- 12" diameter Heavy Duty Casters with Skydrol resistant tread
- Tow Handle with 3" Lunette Eye for towing
- All unpainted parts are plated to resist corrosion
- Skydrol Resistant Paint (safety yellow)
- Factory Proof Load @ 125% of rated capacity
- 1 Year Warranty
- Shipping Skid

Model 95L5.0 is built to withstand harsh environmental conditions, rugged use and to provide many years of continuous service. Our customers are guaranteed a quality product with each purchase and are assured of our continued product support whenever and wherever the need arises.

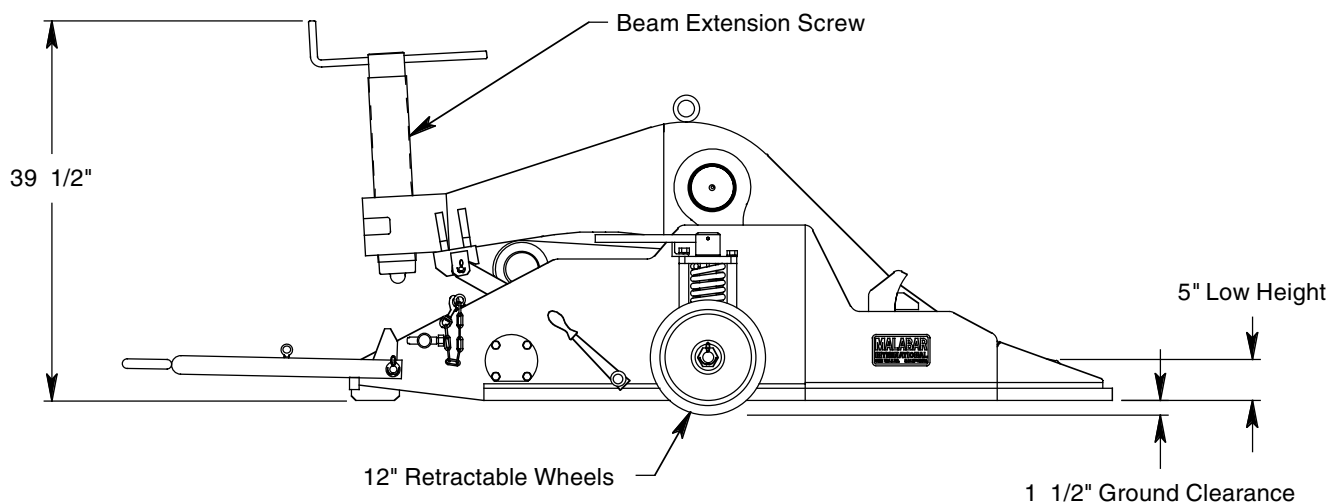
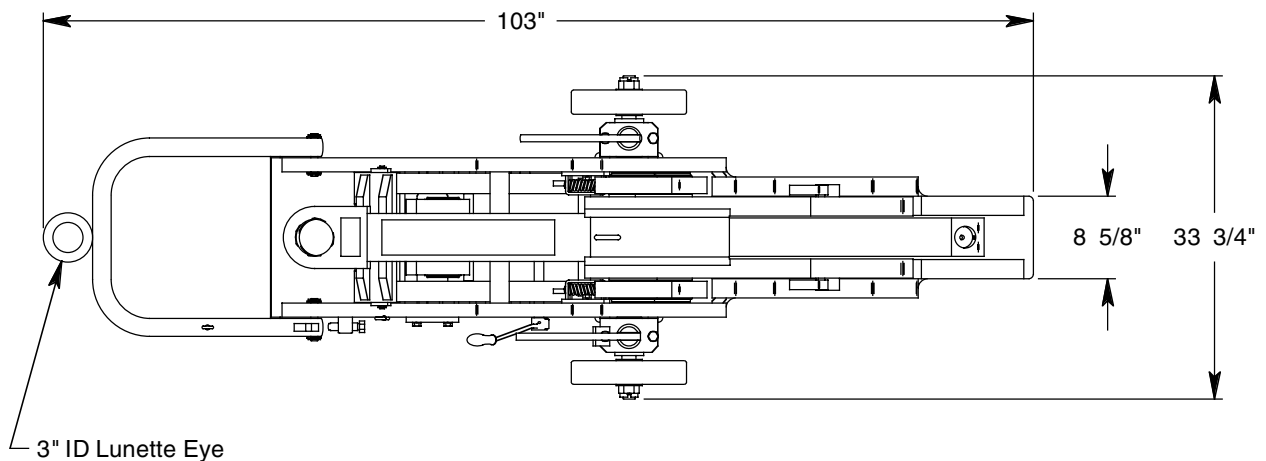

MODEL 95L5.0 95 TON FLOATING BEAM ASSEMBLY

SPECIFICATIONS

Rated Capacity:	95 tons (86.2 m. tons)
Low Height with standard adapter:	5.0 inches (127 mm)
Low Height with 747 NLG adapter:	9.5 inches (241 mm)
Lift (provided by Malabar jack/beam extension screw):	18.5 inches (470 mm)
Total Extended Height with standard adapter:	23.5 inches (597 mm)
Total Extended Height with 747 NLG adapter:	28 inches (711 mm)
Base Width (under jack point):	8.6 inches (220 mm)
Beam Width (under jack point):	4 inches (102 mm)
Proof Load:	118 tons (107 m. tons)
Maximum Towing Speed	5 mph (8 km/h)
Approximate Beam Net Weight:	3100 lbs (1410 kg)

MODEL 95L5.0 TYPICAL AIRCRAFT APPLICATIONS

Main Landing Gear	Nose Landing Gear
A300, A310, A319, A320, A321, A330 A340, B727, B737, B747, B747-8, B767, B777, DC8, DC10, L1011, MD11	A300, A310, A330, A340, B727, B747 B747-8, B767, B777, L1011

OPTIONAL EQUIPMENT CODE: (Specify at time of order)

SPC: Special Paint Color (yellow is standard)

BEAM ACCESSORIES: (Order separately)

95P10AR: 95 Ton Axle Jack (provides lift for beam)

887850: Jack Installer tool (aids jack installation into beam)

PACKAGING CODES & OPTIONS: (Specify at time of order)

— : Domestic Skid

EC: Export Crate (Additional Cost)

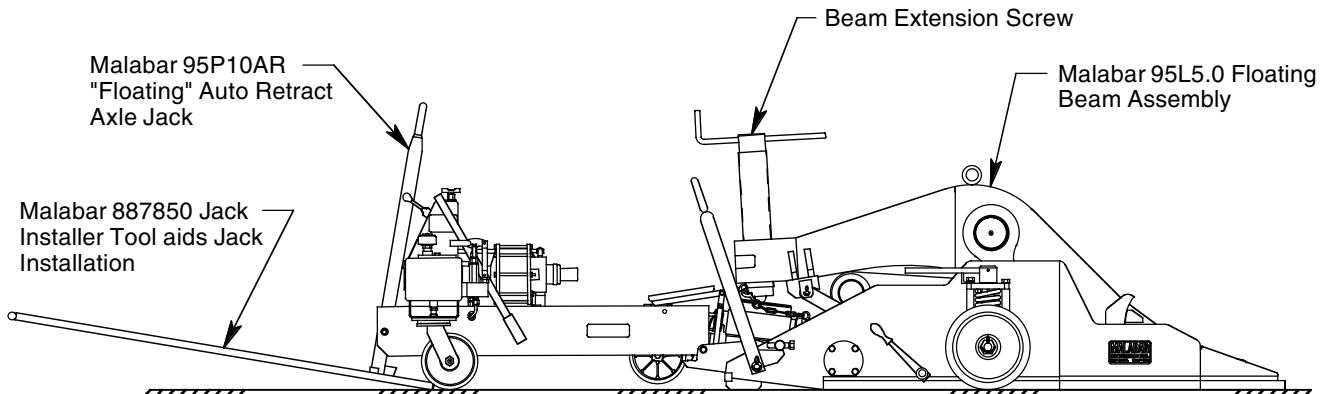

SHIPPING DATA

NOTE: Unless otherwise specified, Model 95L5.0 beam is shipped on a wood skid.

Packaging Code	Length inch (mm)	Width inch (mm)	Height inch (mm)	Weight lbs (kg)
—	90 (2286)	36 (914)	48 (1219)	3200 (1452)
EC	92 (2337)	41 (1041)	51 (1295)	3500 (1588)

MALABAR International

Issue: 2/09

PLANT: 220 WEST LOS ANGELES AVENUE, SIMI VALLEY, CALIFORNIA 93065 · (805) 581-0116 · FAX (805) 584-1624
MAIL: P.O. BOX 367, SIMI VALLEY, CALIFORNIA 93062 · E-mail: sales@malabar.com · Web site: http://www.malabar.com