

MODEL 8876 200 TON UNIVERSAL AXLE JACK TEST STAND

TEST STAND INCLUDES:

- Rugged steel construction
- Lift Rings for easy transportability
- 225 Ton capacity Electronic Load Cell
- Portable Read-out (Digital Indicator)
- 15 Foot long cable to connect portable read-out to load cell
- Battery operated with four standard "D" size batteries
- Easy "zero" and "span" adjustments
- Read-out includes Shunt-cal feature to verify calibration
- Multiple 1/2 inch, 3/4 inch and 1 1/4 inch (12.7, 19.1, and 31.8 mm) spherical radius jack adapters

TEST STAND PURPOSE:

- Test jack cylinder for structural integrity
- Test hydraulic system functionality
- Verify Relief Valve setting/adjustment

INSTALLATION:

Test stand may be installed in ground with base flush with floor or above ground which requires a 4 inch (102 mm) high ramp

Model 8876 is built to withstand harsh environmental conditions, rugged use and to provide many years of continuous service. Our customers are guaranteed a quality product with each purchase and are assured of our continued product support whenever and wherever the need arises.

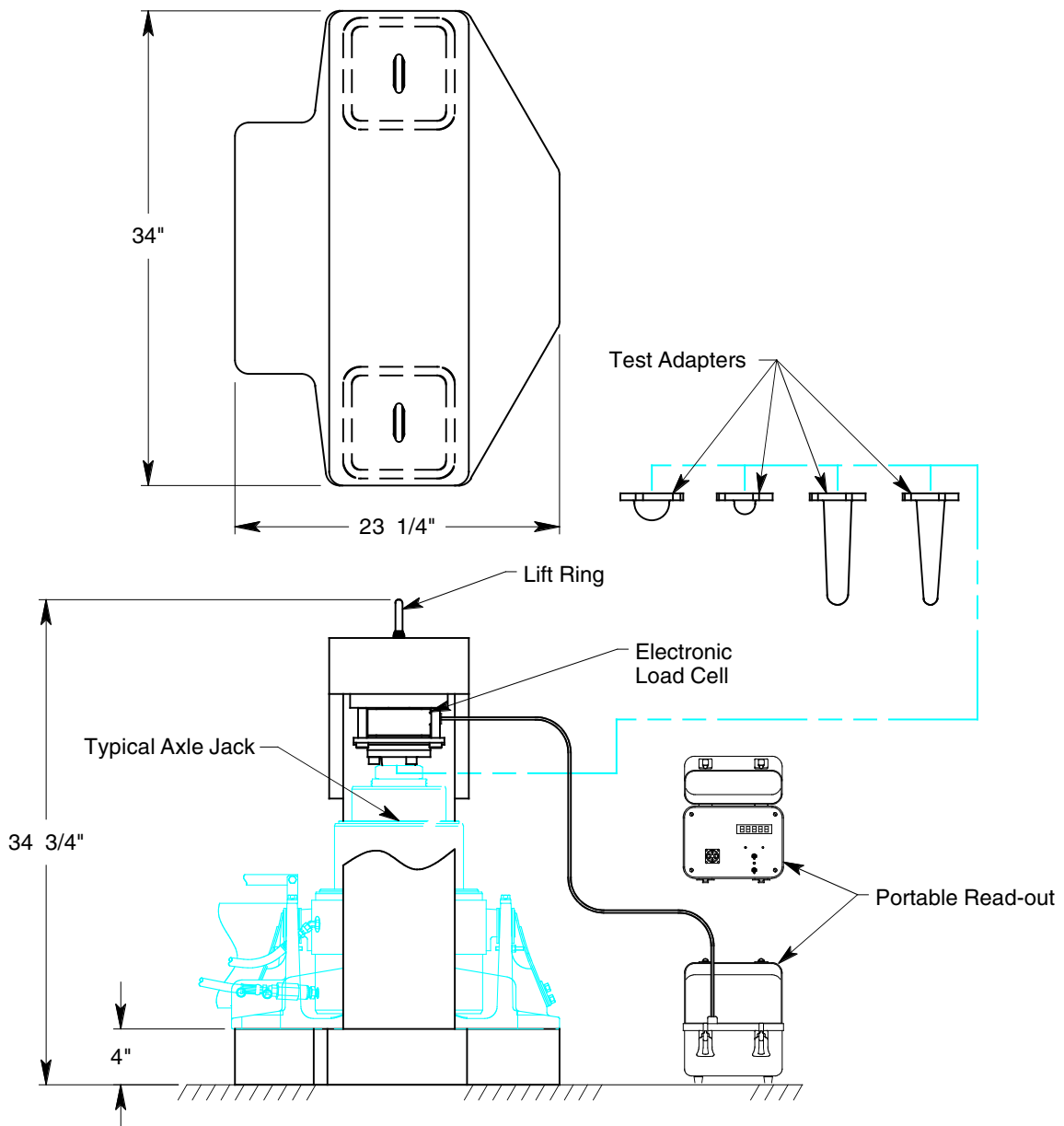

See Reverse Side for Specifications, Options, Aircraft Applications & Shipping Data

MODEL 8876

200 TON UNIVERSAL AXLE JACK TEST STAND

SPECIFICATIONS

Rated Capacity: 200 tons (181 m. tons)
 Roll Under Height with Standard 3/4 Adapter: 18.50 inches (469 mm)
 Roll Under Height with Standard 1 1/4 Adapter: 18.00 inches (458 mm)
 Roll Under Height with Extended Adapters: 12.00 inches (304 mm)
 Standard Jack Adapters Spherical Radius: 1 1/4 & 3/4 inch (31.8 & 19.1 mm)
 Extended Jack Adapters Spherical Radius: 3/4 & 1/2 inch (19.1 & 12.7 mm)
 Test Stand Length: 23.25 inches (591 mm)
 Test Stand Width: 34.00 inches (864 mm)
 Test Stand Height: 34.75 inches (883 mm)
 Approximate Net Weight: 1420 lbs (644 kg)

MODEL 8876 TYPICAL APPLICATIONS

Virtually all mobile and hand carry type aircraft axle jacks

JACK ACCESSORIES: (Order separately)

8876PK: Repair Kit

PACKAGING CODES & OPTIONS: (Specify at time of order)

— : Domestic Skid

EC: Export Crate (Additional Cost)

SHIPPING DATA

NOTE: Unless otherwise specified, Model 8876 is shipped on a wood skid.

Packaging Code	Length inch (mm)	Width inch (mm)	Height inch (mm)	Weight lbs (kg)
—	28 (711)	39 (991)	40 (1016)	1510 (685)
EC	30 (762)	44 (1118)	43 (1092)	1670 (757)