

MODEL 713A 12 TON VARIABLE HEIGHT TRIPOD JACK

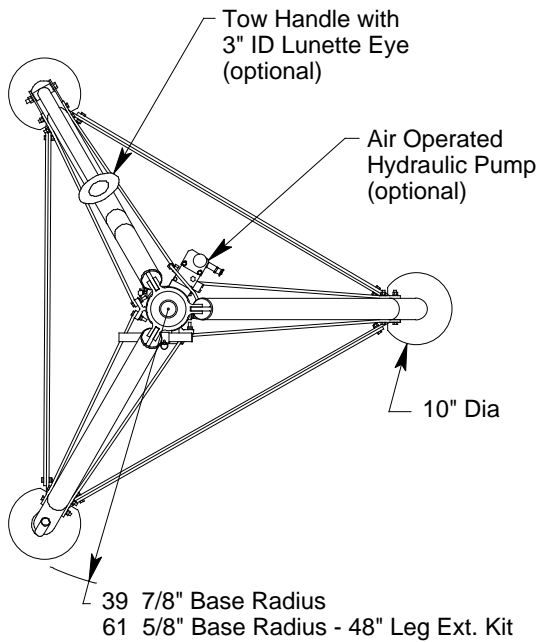

JACK INCLUDES:

- Manual Hand Pump with high, medium and low pressure operating positions
- Heavy Duty Swivel Casters
- Rain Hat (covers jack upper head)
- Hard Chrome Plated Cylinder Bore
- All unpainted parts are plated to resist corrosion
- Skydrol Resistant Paint (safety yellow)
- Factory Proof Load @ 150% of rated capacity
- 3 Year Warranty
- Shipping Skid

STANDARD OPTIONS:

- Air Operated Hydraulic Pump
- Load Gauge for load indication (reads tons/psig)
- Tow Handle for ease of towing
- 48 inch Leg Extension Kit
- Ladder/platform Kit (requires 48 inch leg extension kit)

Model 713A is built to withstand harsh environmental conditions, rugged use and to provide many years of continuous service. Our customers are guaranteed a quality product with each purchase and are assured of our continued product support whenever and wherever the need arises.

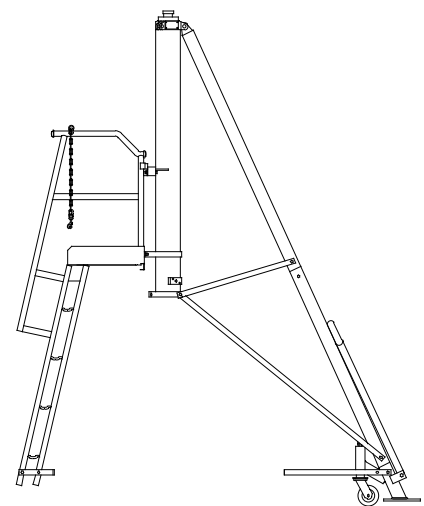
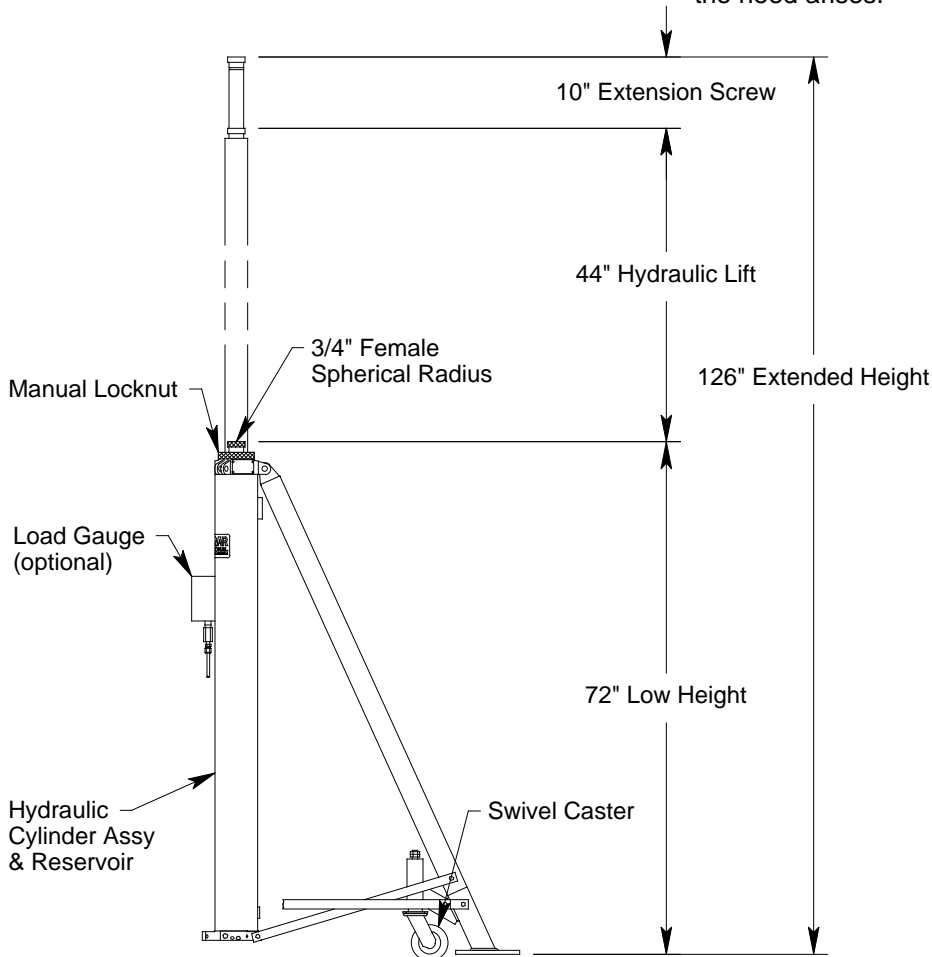

Model 713A shown with 48" Leg Extension Kit & Ladder/platform Kit (optional)

MODEL 713A

12 TON VARIABLE HEIGHT TRIPOD JACK

SPECIFICATIONS

Rated Capacity: 12 tons (10.9 m. tons)
 Side Load: 15% of vertical load
 Roll Under Height: add 1 inch (25 mm) to low heights
 Low Height: 72 inches (1829 mm)
 Low Height with 48" Leg Extension Kit: 120 inches (3048 mm)
 Hydraulic Lift: 44 inches (1118 mm)
 Extension Screw: 10 inches (254 mm)
 Total Extended Height: 126 inches (3200 mm)
 Total Extended Height with 48" Leg Extension Kit: 174 inches (4420 mm)
 Oil Pressure at Rated Capacity: 2470 psig (174 kg/sq cm)
 Safety Pop-off Valve set at: 13.2 tons (12.0 m. tons)
 Proof Load: 18 tons (16.3 m. tons)
 Reservoir Capacity: 3 gallons (11.4 liters)
 Hydraulic Fluid: MIL-H-5606 or equivalent
 Maximum Towing Speed: 5 mph (8 km/h)
 Approximate Jack Net Weight: 750 lbs (340 kg)

MODEL 713A TYPICAL AIRCRAFT APPLICATIONS

Jack Configuration	Forward Fuselage	Mid Wing	Aft Fuselage
713A	B727		
713A with 48" Leg Ext. Kit		B707, B720	A319, A320, A321 B707, B720

OPTIONAL EQUIPMENT CODES: (Specify at time of order)

AP: Air Operated Hydraulic Pump LA: Ladder/platform Kit (requires 48" leg extension kit)
 GA: Load Gauge SPC: Special Paint Color (yellow is standard)
 TH: Tow Handle 713APK: Repair Kit
 48LE: 48" Leg Extension Kit

PACKAGING CODES & OPTIONS: (Specify at time of order)

— : Domestic Skid - Jack Set-up
 KD: Domestic Skid - Jack Knocked Down (Additional Cost)
 LKD: Domestic Skid - Jack & Ladder/platform Kit Knocked Down
 EC: Export Crate - Jack Set-up (Additional Cost)
 ECKD: Export Crate - Jack Knocked Down (Additional Cost)
 ECLKD: Export Crate - Jack & Ladder/platform Kit Knocked Down (Additional Cost)

SHIPPING DATA

NOTE: Unless otherwise specified, Model 713A jack is shipped on a wood skid in the set-up condition. Refer to Malabar Tripod Jack Shipping Supplement for additional packaging information.

Packaging Code	Length inch (mm)	Width inch (mm)	Height inch (mm)	Weight lbs (kg)
—	77 (1956)	66 (1676)	79 (2007)	950 (431)
KD	80 (2032)	40 (1016)	28 (711)	950 (431)
LKD	92 (2337)	40 (1016)	54 (1372)	1200 (544)
EC	79 (2007)	71 (1803)	82 (2083)	1200 (544)
ECKD	82 (2083)	45 (1143)	31 (787)	1100 (499)
ECLKD	94 (2388)	45 (1143)	57 (1448)	1550 (703)

MALABAR International

Issue: 3/99

PLANT: 220 WEST LOS ANGELES AVENUE, SIMI VALLEY, CALIFORNIA 93065 • (805) 581-0116 • FAX (805) 584-1624
 MAIL: P.O. BOX 367, SIMI VALLEY, CALIFORNIA 93062 • E-mail: sales@malabar.com • Web site: http://www.malabar.com