

MODEL 7212B 12 TON FIXED HEIGHT TRIPOD JACK

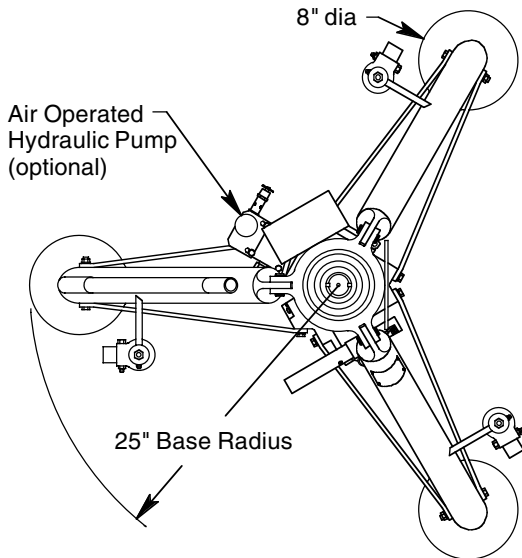

JACK INCLUDES:

- Manual Hand Pump with high, medium and low pressure operating positions
- Heavy Duty Swivel Casters
- Rain Hat (covers jack upper head)
- Hard Chrome Plated Cylinder Bore
- All unpainted parts are plated to resist corrosion
- Skydrol Resistant Paint (safety yellow)
- Factory Proof Load @ 150% of rated capacity
- 3 Year Warranty
- Shipping Skid

STANDARD OPTIONS:

- Air Operated Hydraulic Pump
- Load Gauge for load indication (reads tons/psig)

Model 7212B is built to withstand harsh environmental conditions, rugged use and to provide many years of continuous service. Our customers are guaranteed a quality product with each purchase and are assured of our continued product support whenever and wherever the need arises.

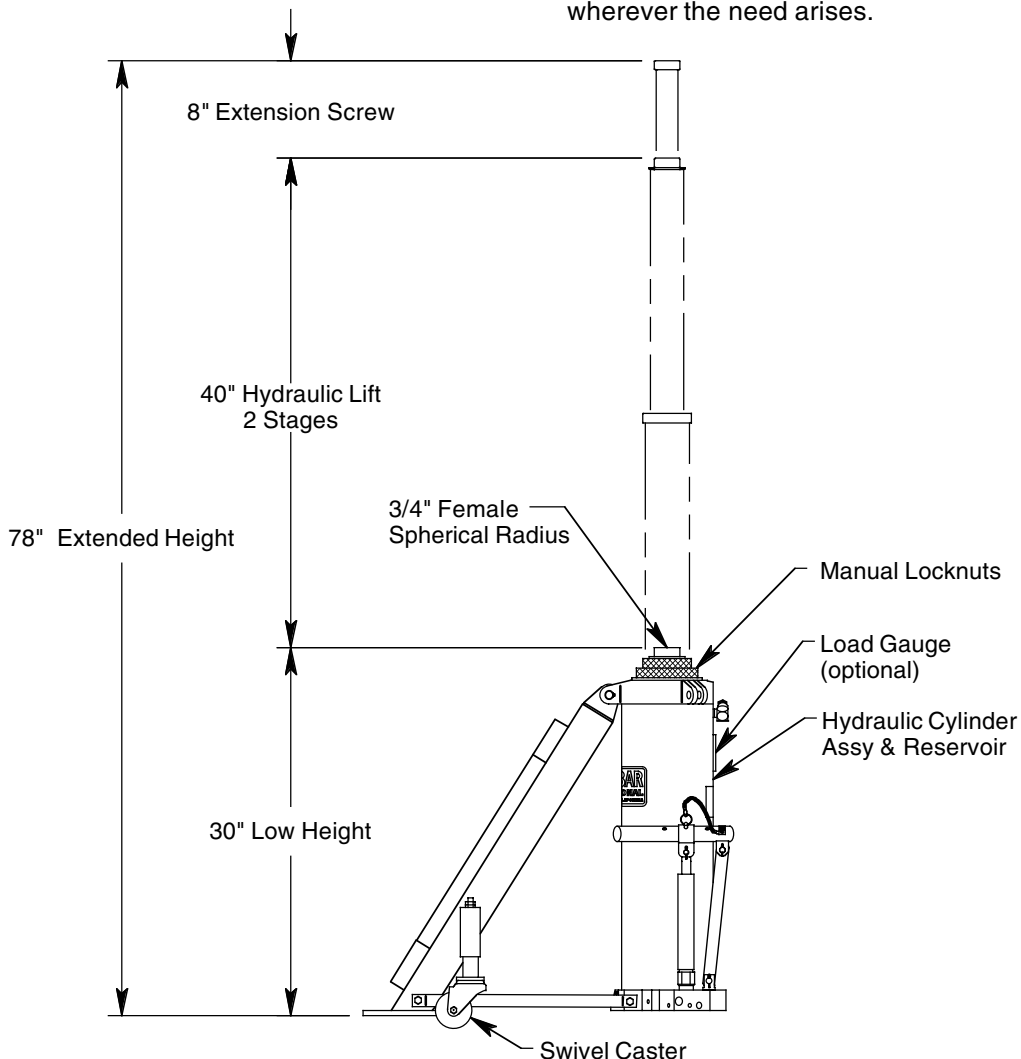

See Reverse Side for Specifications, Options, Aircraft Applications & Shipping Data

MODEL 7212B

12 TON FIXED HEIGHT TRIPOD JACK

SPECIFICATIONS

Rated Capacity: 12 tons (10.9 m. tons)
 Side Load: 15% of vertical load
 Roll Under Height: 31 inches (787 mm)
 Low Height: 30 inches (762 mm)
 Hydraulic Lift: 40 inches (1016 mm)
 Extension Screw: 8 inches (203 mm)
 Total Extended Height: 78 inches (1981 mm)
 Oil Pressure at Rated Capacity: 3400 psig (239 kg/sq cm)
 Safety Pop-off Valve set at: 13 tons (11.8 m. tons)
 Proof Load: 18 tons (16.3 m. tons)
 Reservoir Capacity: 2.2 gallons (8.3 liters)
 Hydraulic Fluid: MIL-H-5606 or equivalent
 Approximate Jack Net Weight: 330 lbs (150 kg)

MODEL 7212B TYPICAL AIRCRAFT APPLICATIONS

Forward Fuselage	Wing	Aft Fuselage
B717, DC9, Jetstar, MD80, MD90	C601, C602, CRJ, Jetstar, Falcon 10, Falcon 20, Falcon 50, Falcon 100	ATR42, ATR72, B717, DC9 with aft stair

OPTIONAL EQUIPMENT CODES: (Specify at time of order)

AP: Air Operated Hydraulic Pump
 GA: Load Gauge
 SPC: Special Paint Color (yellow is standard)
 7212BPK: Repair Kit

PACKAGING CODES & OPTIONS: (Specify at time of order)

— : Domestic Skid - Jack Set-up
 EC: Export Crate - Jack Set-up (Additional Cost)

SHIPPING DATA

NOTE: Unless otherwise specified, Model 7212B jack is shipped on a wood skid in the set-up condition. Refer to Malabar Tripod Jack Shipping Supplement for additional packaging information.

Packaging Code	Length inch (mm)	Width inch (mm)	Height inch (mm)	Weight lbs (kg)
—	52 (1321)	47 (1194)	38 (965)	395 (179)
EC	54 (1372)	52 (1321)	41 (1041)	560 (254)