

**MODEL 759A**  
**50 TON FIXED HEIGHT TRIPOD JACK**

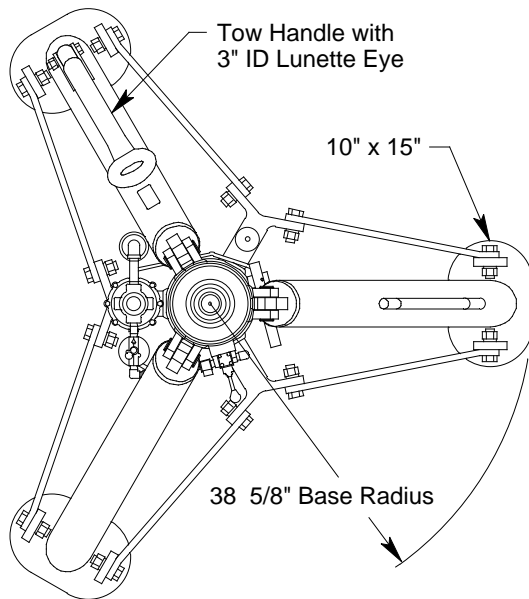

**JACK INCLUDES:**

- Manual Hand Pump with high, medium and low pressure operating positions
- Heavy Duty Tow Handle and Swivel Casters with Swivel Locks for improved towing
- Secondary Cylinder Seal for protection against contaminants and to prolong life of primary seal
- Rain Hat (covers jack upper head)
- Hard Chrome Plated Cylinder Bore
- All unpainted parts are plated to resist corrosion
- Skydrol Resistant Paint (safety yellow)
- Factory Proof Load @ 150% of rated capacity
- 3 Year Warranty
- Shipping Skid

**STANDARD OPTIONS:**

- Air Operated Hydraulic Pump
- Load Gauge for load indication (reads tons/psig)
- Adjustable Swivel Feet with Level for leveling jack

Model 759A is built to withstand harsh environmental conditions, rugged use and to provide many years of continuous service. Our customers are guaranteed a quality product with each purchase and are assured of our continued product support whenever and wherever the need arises.

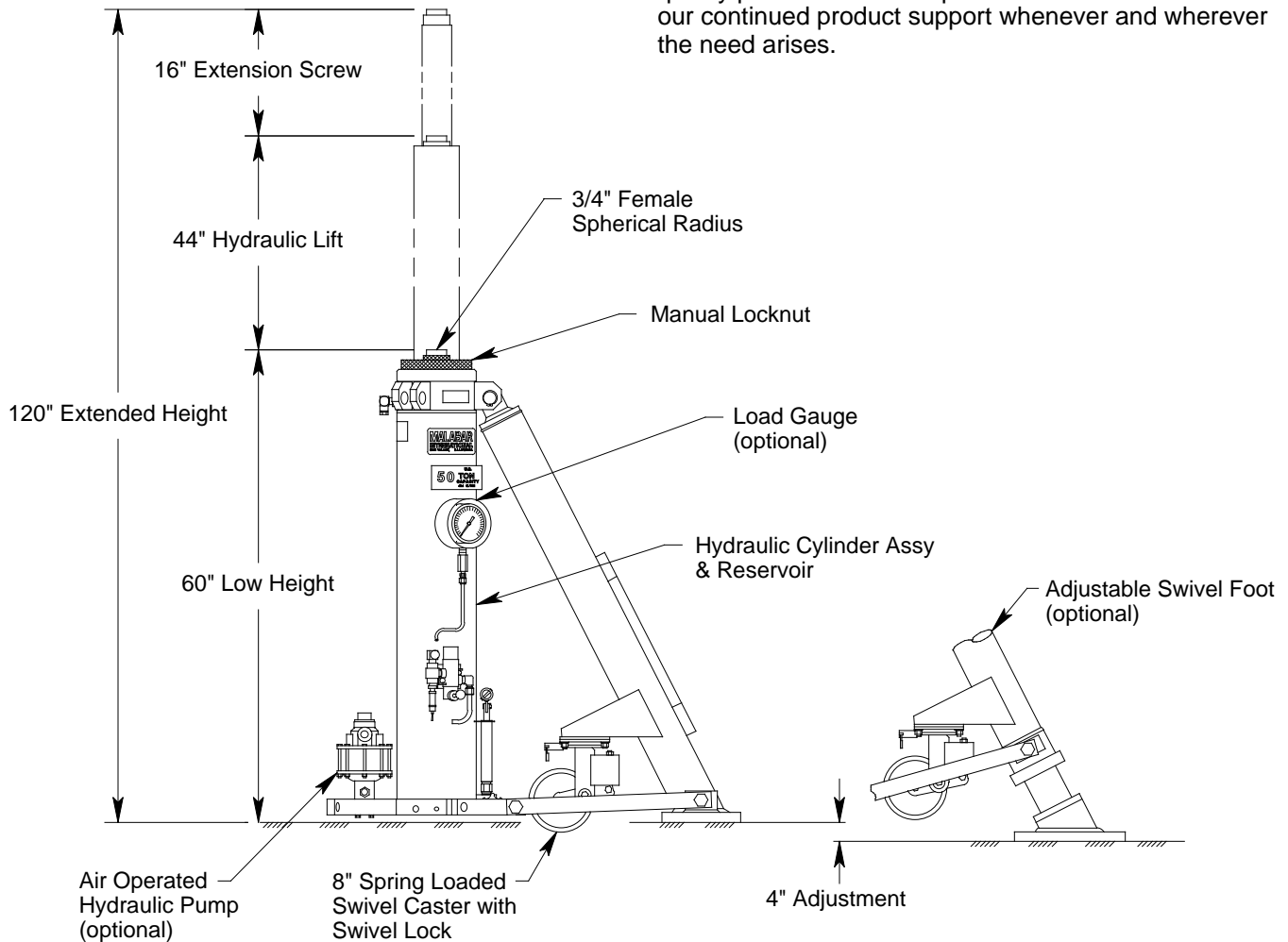

See Reverse Side for Specifications, Options, Aircraft Applications & Shipping Data

# MODEL 759A

## 50 TON FIXED HEIGHT TRIPOD JACK

### SPECIFICATIONS

Rated Capacity: 50 tons (45.4 m. tons)  
 Side Load: 15% of vertical load  
 Roll Under Height: 61.5 inches (1562 mm)  
 Low Height: 60 inches (1524 mm)  
 Hydraulic Lift: 44 inches (1118 mm)  
 Extension Screw: 16 inches (406 mm)  
 Total Extended Height: 120 inches (3048 mm)  
 Oil Pressure at Rated Capacity: 3228 psig (227 kg/sq cm)  
 Safety Pop-off Valve set at: 55 tons (49.9 m. tons)  
 Proof Load: 75 tons (68.0 m. tons)  
 Reservoir Capacity: 6.1 gallons (23.1 liters)  
 Hydraulic Fluid: MIL-H-5606 or equivalent  
 Maximum Towing Speed: 5 mph (8 km/h)  
 Approximate Jack Net Weight: 1700 lbs (771 kg)

### MODEL 759A TYPICAL AIRCRAFT APPLICATIONS

Wing

B707, B720, B727, B737, DC8, DC9, F100, MD80, MD90

#### OPTIONAL EQUIPMENT CODES: (Specify at time of order)

AP: Air Operated Hydraulic Pump  
 GA: Load Gauge  
 AF: Adjustable Swivel Foot  
 SPC: Special Paint Color (yellow is standard)  
 759APK: Repair Kit

#### PACKAGING CODES & OPTIONS: (Specify at time of order)

— : Domestic Skid - Jack Set-up  
 KD: Domestic Skid - Jack Knocked Down (Additional Cost)  
 EC: Export Crate - Jack Set-up (Additional Cost)  
 ECKD: Export Crate - Jack Knocked Down (Additional Cost)

### SHIPPING DATA

NOTE: Unless otherwise specified, Model 759A jack is shipped on a wood skid in the set-up condition. Refer to Malabar Tripod Jack Shipping Supplement for additional packaging information.

Packaging Code	Length inch (mm)	Width inch (mm)	Height inch (mm)	Weight lbs (kg)
—	77 (1956)	66 (1676)	67 (1702)	1950 (885)
KD	78 (1981)	40 (1016)	42 (1067)	1950 (885)
EC	79 (2007)	71 (1803)	70 (1778)	2200 (998)
ECKD	80 (2032)	45 (1143)	45 (1143)	2250 (1021)