

# MODEL 8487A 5 TON VARIABLE HEIGHT TRIPOD JACK

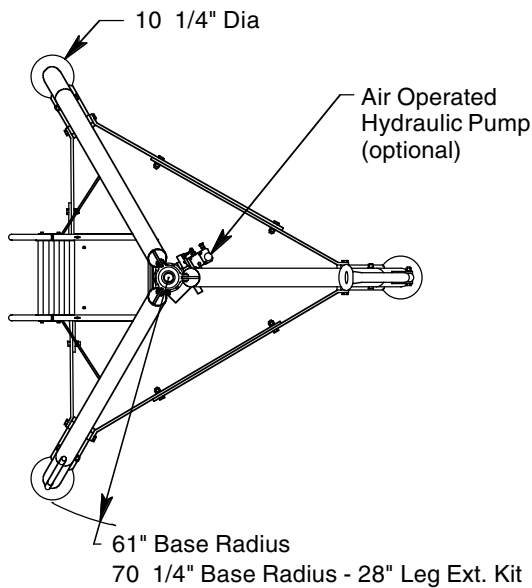

**JACK INCLUDES:**

- Manual Hand Pump with high, medium and low pressure operating positions
- Heavy Duty Swivel Casters with swivel locks
- Rain Hat (covers jack upper head)
- Hard Chrome Plated Cylinder Bore
- All unpainted parts are plated to resist corrosion
- Skydrol Resistant Paint (safety yellow)
- Factory Proof Load @ 150% of rated capacity
- 3 Year Warranty
- Shipping Skid

**STANDARD OPTIONS:**

- Air Operated Hydraulic Pump
- Load Gauge for load indication (reads tons/psig)
- Tow Handle for ease of towing
- 28 inch Leg Extension Kit
- Platform Mounted Operating Controls allow one person to position locknut while controlling lifting and lowering operations
- Ladder/platform

Model 8487A is built to withstand harsh environmental conditions, rugged use and to provide many years of continuous service. Our customers are guaranteed a quality product with each purchase and are assured of our continued product support whenever and wherever the need arises.

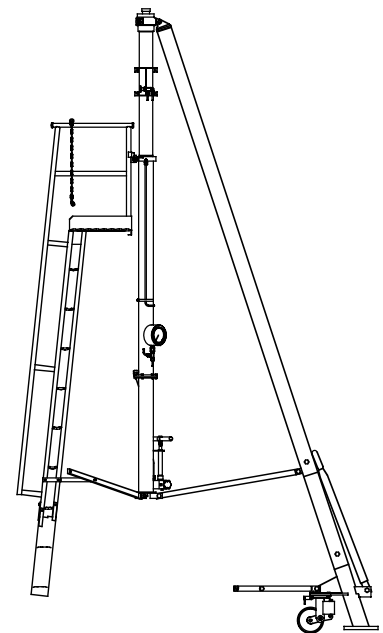
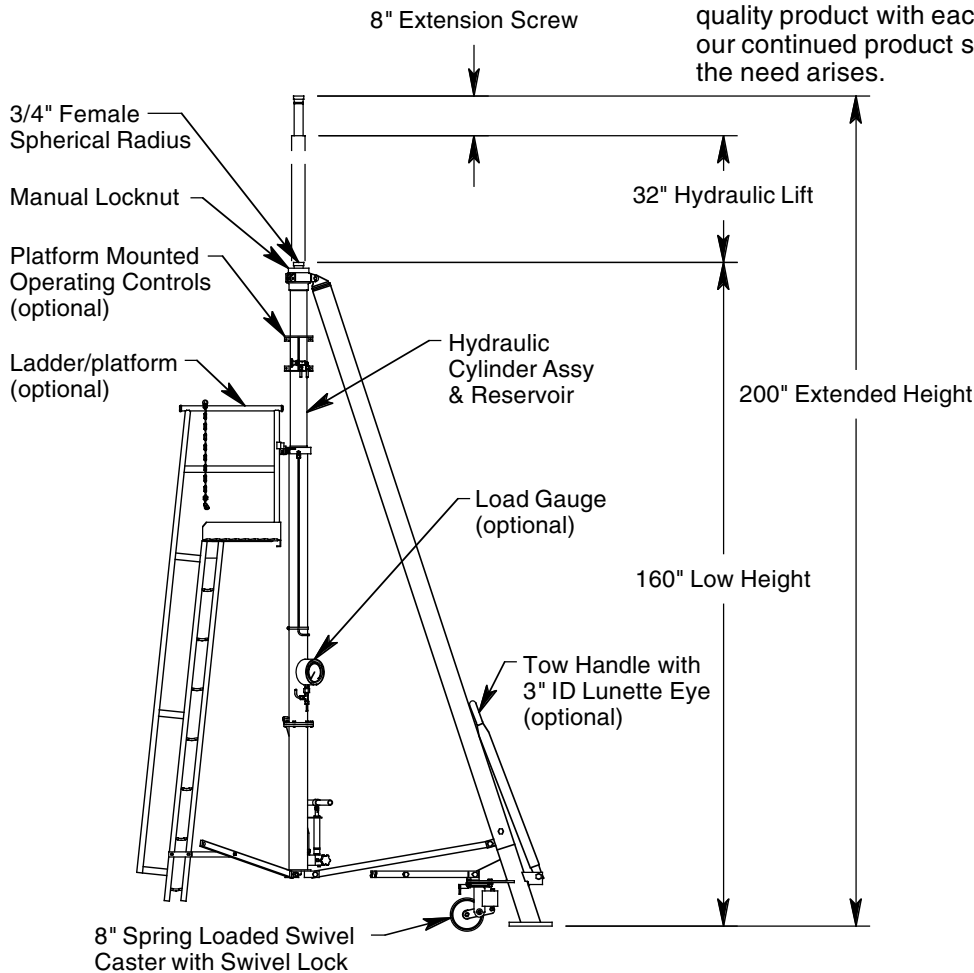

Model 8487A shown with 28" Leg Extension Kit (optional)

[See Reverse Side for Specifications, Options, Aircraft Applications & Shipping Data](#)

# MODEL 8487A

## 5 TON VARIABLE HEIGHT TRIPOD JACK

### SPECIFICATIONS

Rated Capacity: 5 tons (4.5 m. tons)  
 Side Load: 15% of vertical load  
 Roll Under Height: 161.5 inches (4102 mm)  
 Roll Under Height with 28" Leg Extension: 189.5 inches (4813 mm)  
 Low Height: 160.0 inches (4064 mm)  
 Low Height with 28" Leg Extension: 188.0 inches (4775 mm)  
 Hydraulic Lift: 32 inches (813 mm)  
 Extension Screw: 8 inches (203 mm)  
 Total Extended Height: 200 inches (5080 mm)  
 Total Extended Height with 28" Leg Extension: 228 inches (5791 mm)  
 Oil Pressure at Rated Capacity: 1030 psig (72 kg/sq cm)  
 Safety Pop-off Valve set at: 5.5 tons (5.0 m. tons)  
 Proof Load: 7.5 tons (6.8 m. tons)  
 Reservoir Capacity: 1.8 gallons (6.8 liters)  
 Hydraulic Fluid: MIL-H-5606 or equivalent  
 Maximum Towing Speed: 5 mph (8 km/h)  
 Approximate Jack Net Weight: 1150 lbs (522 kg)

### MODEL 8487A TYPICAL AIRCRAFT APPLICATIONS

Jack Configuration	Aft Fuselage
8487A	A310
8487A with 28" Leg Extension Kit	A300

**OPTIONAL EQUIPMENT CODES:** (Specify at time of order)

AP: Air Operated Hydraulic Pump  
 GA: Load Gauge  
 TH: Tow Handle  
 LE: 28" Leg Extension Kit  
 LA: Ladder/platform Kit  
 RC: Platform Mounted Operating Controls  
 SPC: Special Paint Color (yellow is standard)  
 8487APK: Repair Kit

**PACKAGING CODES & OPTIONS:** (Specify at time of order)

KD: Domestic Skid - Jack Knocked Down  
 ECKD: Export Crate - Jack Knocked Down (Additional Cost)

### SHIPPING DATA

NOTE: Unless otherwise specified, Model 8487A jack is shipped on a wood skid in the knocked down condition. Refer to Malabar Tripod Jack Shipping Supplement for additional packaging information.

Packaging Code	Length inch (mm)	Width inch (mm)	Height inch (mm)	Weight lbs (kg)
KD	192 (4877)	40 (1016)	42 (1067)	1500 (680)
ECKD	194 (4928)	45 (1143)	45 (1143)	1900 (862)