

MODEL 8803A
15 TON FIXED HEIGHT TRIPOD JACK

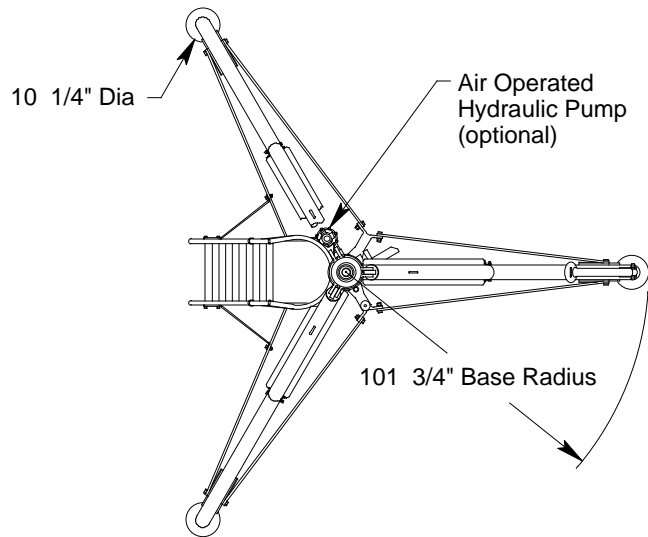

JACK INCLUDES:

- Manual Hand Pump with high, medium and low pressure operating positions
- Heavy Duty Tow Handle and Swivel Casters with Swivel Locks for improved towing
- Hydraulic "Thermal" Relief Valve for added protection and safety in the event of internal fluid expansion due to temperature
- Secondary Cylinder Seal for protection against contaminants and to prolong life of primary seal
- Rain Hat (covers jack upper head)
- Hard Chrome Plated Cylinder Bore
- All unpainted parts are plated to resist corrosion
- Skydrol Resistant Paint (safety yellow)
- Factory Proof Load @ 150% of rated capacity
- 3 Year Warranty
- Shipping Skid

STANDARD OPTIONS:

- Air Operated Hydraulic Pump
- Load Gauge for load indication (reads tons/psig)
- Adjustable Swivel Feet with Level for leveling jack
- Ladder/platform

Model 8803A is built to withstand harsh environmental conditions, rugged use and to provide many years of continuous service. Our customers are guaranteed a quality product with each purchase and are assured of our continued product support whenever and wherever the need arises.

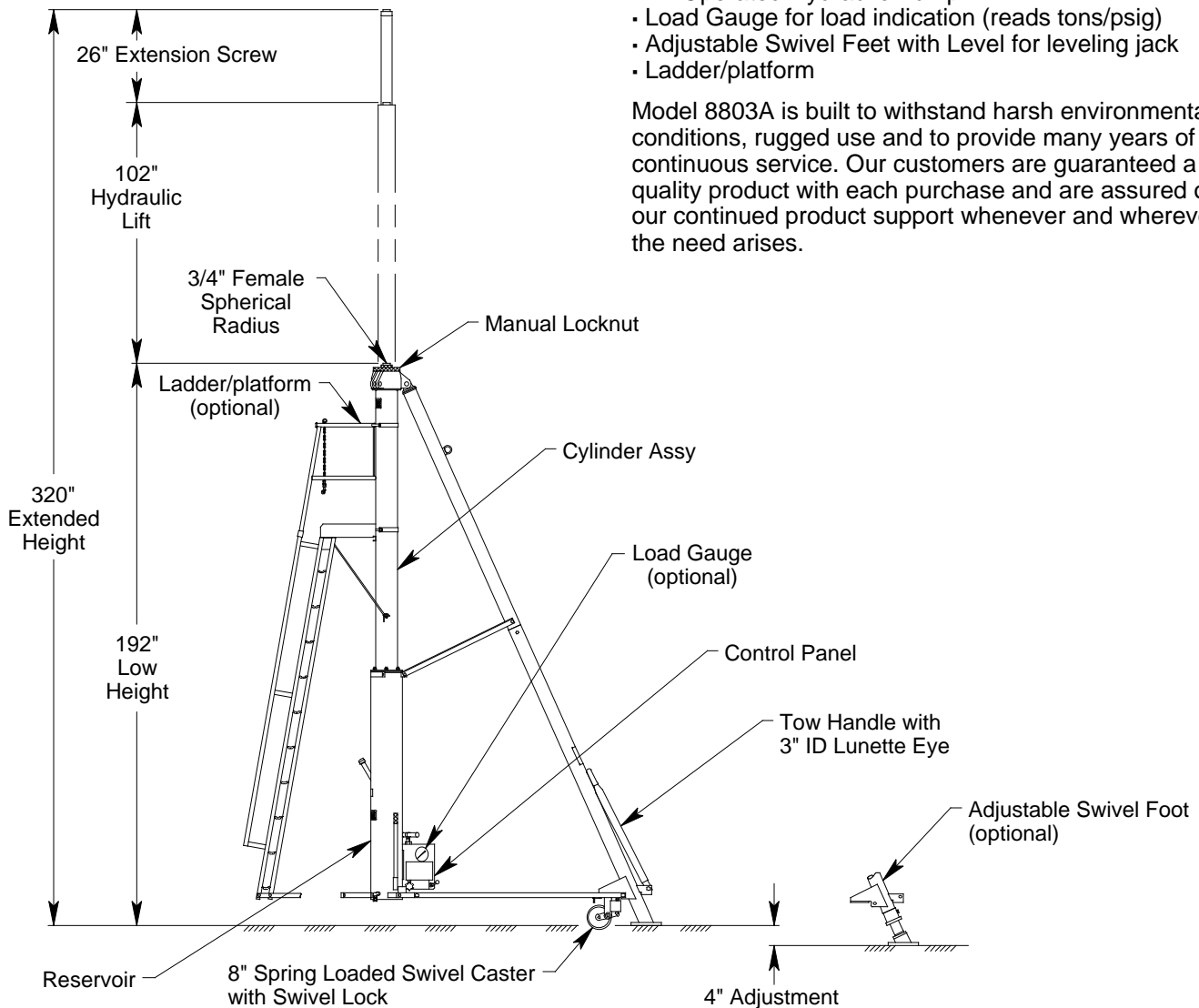

See Reverse Side for Specifications, Options, Aircraft Applications & Shipping Data

MODEL 8803A

15 TON FIXED HEIGHT TRIPOD JACK

SPECIFICATIONS

Rated Capacity: 15 tons (13.6 m. tons)
 Side Load: 15% of vertical load
 Roll Under Height: 193.5 inches (4915 mm)
 Low Height: 192 inches (4877 mm)
 Hydraulic Lift: 102 inches (2591 mm)
 Extension Screw: 26 inches (660 mm)
 Total Extended Height: 320 inches (8128 mm)
 Oil Pressure at Rated Capacity: 984 psig (69 kg/sq cm)
 Safety Pop-off Valves
 System Relief Valve set at: 16.5 tons (15.0 m. tons)
 Thermal Relief Valve set at: 18.8 tons (17.1 m. tons)
 Proof Load: 22.5 tons (20.4 m. tons)
 Reservoir Capacity: 14.4 gallons (54.5 liters)
 Hydraulic Fluid: MIL-H-5606 or equivalent
 Maximum Towing Speed: 5 mph (8 km/h)
 Approximate Jack Net Weight: 2900 lbs (1315 kg)

MODEL 8803A TYPICAL AIRCRAFT APPLICATIONS

Wing Tip

B747, B777

OPTIONAL EQUIPMENT CODES: (Specify at time of order)

AP: Air Operated Hydraulic Pump
 GA: Load Gauge
 AF: Adjustable Swivel Foot
 LA: Ladder/platform
 SPC: Special Paint Color (yellow is standard)
 8803APK: Repair Kit

PACKAGING CODES & OPTIONS: (Specify at time of order)

KD: Domestic Skid - Jack Knocked Down
 ECKD: Export Crate - Jack Knocked Down (Additional Cost)

SHIPPING DATA

NOTE: Unless otherwise specified, Model 8803A jack is shipped on a wood skid in the knocked down condition. Refer to Malabar Tripod Jack Shipping Supplement for additional packaging information.

Packaging Code	Length inch (mm)	Width inch (mm)	Height inch (mm)	Weight lbs (kg)
KD	217 (5512)	40 (1016)	44 (1118)	3200 (1452)
ECKD	219 (5563)	45 (1143)	47 (1194)	3600 (1633)